

REF. #	DESCRIPTIONS	HVI-88 (7/8")	HVI-82 (1 1/4")	IOM-96(1 7/16")
	PUMP ARM COMPLETE	014-202	007-030	015-200
	COMPLETE ECCENTRIC	*021-035	*021-035	*021-035B
17	ECCENTRIC W / CAPACITY SCALE	021-037	021-037	021-037B
	CAPACITY SCALE	021-041	021-041	021-041
	ROUND HEAD U-DRIVE SCREW (2X)	043-018	043-018	043-018
18	ECCENTRIC ADJUSTING SCREW	021-104	021-104	021-104
19	ECCENTRIC SET SCREW LONG	043-019	043-019	043-019
20	ECCENTRIC ROLL PIN	021-108	021-108	021-108
21	ECCENTRIC KEY	044-123	044-123	044-123
22	ECCENTRIC SET SCREW SHORT	043-049	043-049	043-049
23	ECCENTRIC TEE BOLT	021-100	021-100	021-100
24	WASHER AND POINTER ASSY.	021-049	021-049	021-049
25	ECCENTRIC LOCK NUT	021-101	021-101	021-101
	BEARING ASSY. COMPLETE	*021-048	*021-048	*021-048
26	ECCENTRIC CONNECTING ROD BEARING	021-044	021-044	021-044
27	ECCENTRIC GREASE FITTING	021-152	021-152	021-152
28	CONNECTING ROD JAM NUT	043-072	043-072	043-072
29	CROSSHEAD CONNECTING ROD BEARING	021-047	021-047	021-047
30	PISTON RETAINING SCREW	021-103	021-103	021-103
31	LOCKWASHER (PISTON RETAINING SCREW)	021-099	021-099	021-099
32	CROSSHEAD CLEVIS PIN	021-102	021-102	021-102
33	CROSSHEAD	021-076	021-076	021-076
34	PUMP FRAME MOUNTING BOLT (3X)	043-022	043-022	043-022
35	PUMP FRAMECASTING	*021-032	*021-032	*021-032
36	PUMP FRAME GREASE FITTING	021-051	021-051	021-051
37	PISTON	014-300	051-052	015-300
38	O-RINGS (2X)	014-302	055-071	015-310
39	CYLINDER SET SCREW JAM NUT	043-067	043-067	043-067
40	CYLINDER SET SCREW	043-112	043-112	043-112
41	CYLINDER PURGE PORT PLUG	021-053	021-053	021-053
42	CYLINDER	014-301	051-051	015-301
43	PUMP VALVE ASSY. (2X)	*021-285	*055-069	*055-069
44	VALVE BALL	021-286	055-066	055-066
45	VALVE SPRING	N/A	055-068	055-068
46	RETAINING RING (2X)	021-287	055-067	055-067
1	BASE PLATE - NEMA 48	021-024	021-024	021-024
2	ELECTRIC MOTOR SUPPORT BOLTS (4X)	043-024	043-024	043-024
3	5/16" WASHER - ELECTRIC MOTOR (4X)	043-093	043-093	043-093
4	MOTOR MOUNTING BOLTS (4X)	043-025	043-025	043-025
5	ELEC. MOTOR 1/3 HP THREE PHASE	044-001	044-001	044-001
	ELEC. MOTOR 1/2 HP THREE PHASE(IOM-96 DUPLEX ONLY)			044-021
	ELEC. MOTOR 1/3 HP SINGLE PHASE	044-002	044-002	044-002
	MOTOR COUPLER ASSY. 1/2" x 5/8"	*044-118	*044-118	*044-118
6	MOTOR COUPLER END 1/2" W/O KEYWAY (MOTOR)	044-120	044-120	044-120
7	SPIDER INSERT 3 JAW	044-121	044-121	044-121
8	MOTOR COUPLER END 5/8" JAW (GEAR REDUCER)	044-147	044-147	044-147
9	MOTOR COUPLING KEY	044-123	044-123	044-123
10	GEAR REDUCER 15:1 (BREAKDOWN ON SEPARATE SHEET)	021-016	021-016	021-016
11	BREATHER VENT	021-112	021-112	021-112
12	BUSHING 1/4" X 1/8"	045-130	045-130	045-130
13	NAME PLATE FOR MODEL AND SERIAL #'S	021-026	021-026	021-026
14	ROUND HEAD U-DRIVE SCREW (2X) FOR NAME PLATE	043-018	043-018	043-018
15	GEAR REDUCER BOLT (4X)	043-017	043-017	043-017

GEAR REDUCER PARTS

MODELS: I-70, HVI-88, HVI-82, AND IOM-96

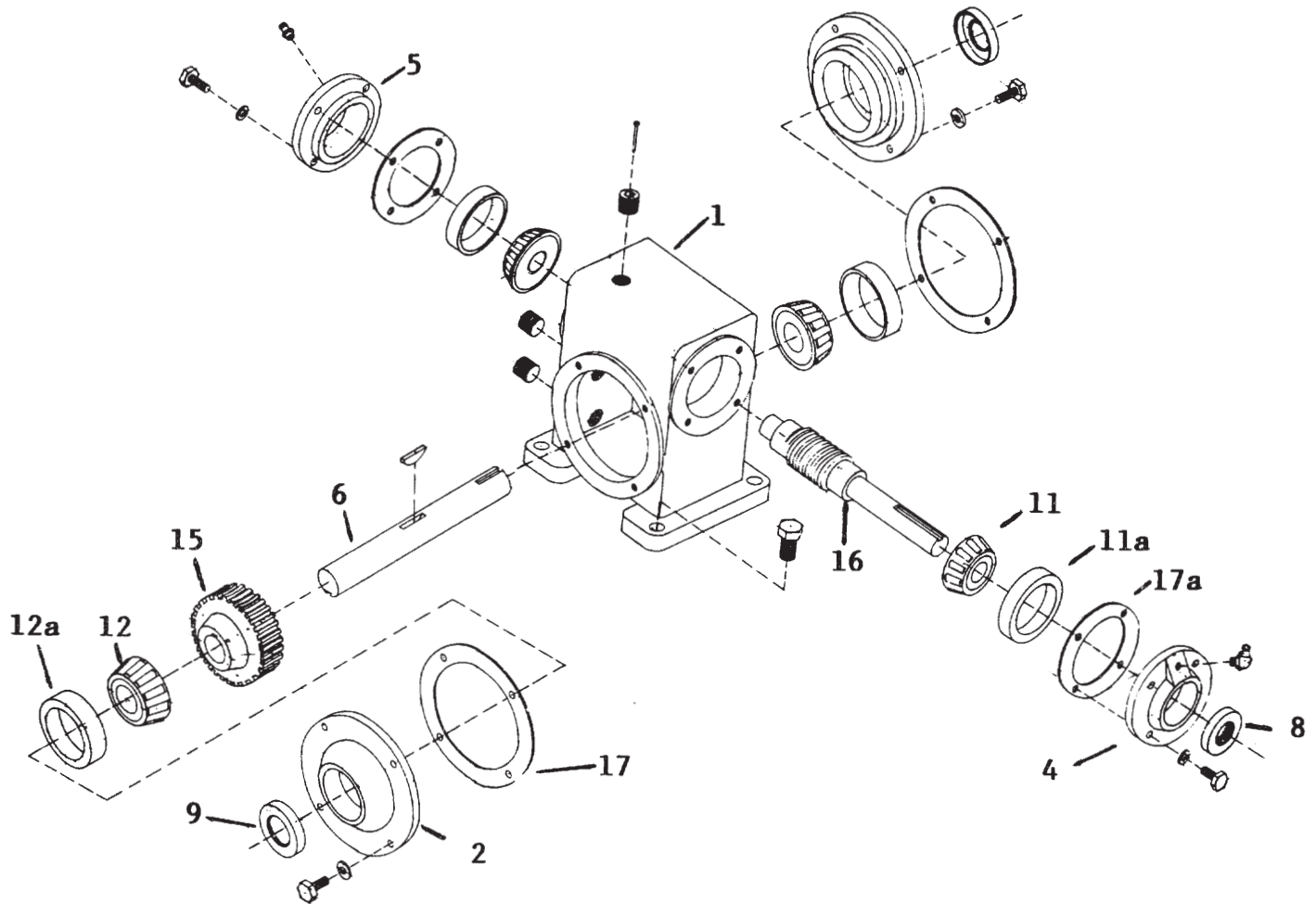

PART NO.	REF. NO.	DESCRIPTION
021-015	1	HOUSING
021-014	2	SLOW SPEED COVER – OPEN
021-012	4	HIGH SPEED COVER – OPEN
021-011	5	HIGH SPEED COVER – CLOSED
021-010	6	SLOW SPEED SHAFT (DBL EXTENTION) HARDENED
021-007	8	HIGH SPEED OIL SEAL
021-006	9	SLOW SPEED OIL SEAL
021-005	11	ROLLER BEARING – HIGH SPEED SINGLE ROW
021-147	11A	ROLLER BEARING RACE – HIGH SPEED
021-004	12	ROLLER BEARING – SLOW SPEED
021-146	12A	ROLLER BEARING RACE – SLOW SPEED
021-002	15	SLOW SPEED WORM GEAR – BRONZE
021-001	16	HIGH SPEED WORM SHAFT – INTEGRAL
021-202	17	GASKETS – SLOW SPEED (2 REQUIRED)
021-205	17A	GASKETS – HIGH SPEED (2 REQUIRED)
042-130		GEAR OIL, CALLON