

## 9343P-GM6-SP and 9343P-GM10-SP Hydraulic-Driven, Self-priming, Polypropylene Transfer Pumps

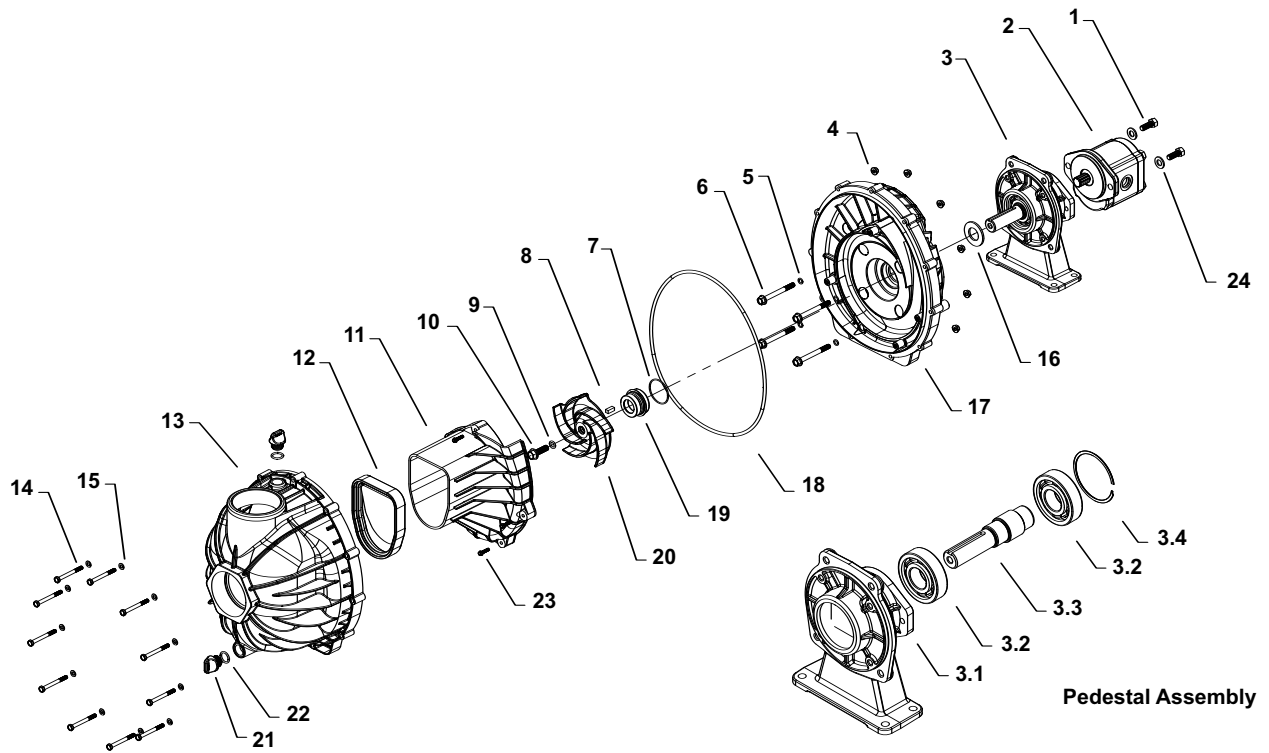

**Seal Repair Kit 3430-0757 contains:**

(4) Ref. 3 O-ring, (1) Ref. 5 Mechanical Seal O-ring, (1) Ref. 17 Mechanical Seal, (1) Ref. 7 Impeller O-ring, (1) Ref. 10 Flapper, and (1) Ref. 16 Body O-ring.

**Pedestal Assembly 0751-9343A contains:**

(1) Ref. 3.1 Pedestal, (2) Ref. 3.2 Ball Bearing, (1) Ref. 3.3 Pump Shaft, and (1) Ref. 3.4 Snap Ring.

**Ref # Torque Spec.**

#1 10 ft.-lbs.  
#6 10 ft.-lbs.  
#10 10 ft.-lbs.  
#14 45 in.-lbs.  
#23 24 in.-lbs.

**Pump Head Kit 3430-0692** Includes all items less the mounting bolts (Ref. 1), motor (Ref. 2), and pedestal (Ref. 3).

**Motor Repair Kit 3430-0788 for GM6 and GM10** Includes all seal and gasket components.

Ref. No.	Qty.	Part No.	Description
1	2	2220-0004	Socket Head Screw
2	1	2500-0075	Hydraulic Motor 11.5 cc (GM6)
2A	1	2500-0117	Hydraulic Motor 16 cc (GM10)
3	1	0751-9343A	Pedestal Assembly, Splined Shaft
4	11	2250-0087	Hex Flange Nut
5	4	1723-0149	O-ring
6	4	2210-0182	Hex Flange Bolt
7	1	1723-0148	O-ring
8	1	1610-0069	Key (square)
9	1	1723-0142	O-ring
10	1	2210-0181	Hex Flange Bolt
11	1	0150-1543P	Pump Volute
12	1	1700-0232	Flapper Valve

Ref. No.	Qty.	Part No.	Description
13	1	0100-1543P	Pump Housing
14	11	2210-0141	Hex Head Cap Screw
15	11	2270-0115	Flat Washer
16	1	1410-0091	Slinger Ring
17	1	0750-1543P	Back Plate
18	1	1723-0146	O-ring
19	1	2120-0055	Mechanical Seal
20	1	0400-1543P	Impeller
21	2	2404-0350P	Fill/Drain Plug
22	2	1720-0230	O-ring
23	4	2210-0183	Hex Washer Head Screw
24	2	2270-0137	Washer





## General Safety Information

### NOTE

Notes are used to notify of installation, operation, or maintenance information that is important but not safety related.

### CAUTION

Caution is used to indicate the presence of a hazard, which will or may cause minor injury or property damage if the notice is ignored.

### DANGER

Self-priming pumps are capable of extremely high levels of suction. Be sure when drawing from an open tank, pool, or pond that it is evacuated prior to operation. Install basket strainer to prevent debris or small species from being pulled into the suction line.

Do not pump flammable or explosive fluids such as gasoline, fuel oil, kerosene, etc. Do not use in explosive atmospheres. Components not rated for use with Anhydrous Ammonia. The pump should only be used with liquids compatible with the pump materials. Failure to follow this notice may result in severe personal injury and/or property damage and will void the product warranty.

Engine emits toxic carbon monoxide fumes. Never run in an enclosed area. Outdoor use only.

### WARNING

The sound pressure level of the pump may exceed 80dBA. Observe all safety precautions when operating the pump within close proximity for extended periods by wearing hearing protectors. Extended exposure to elevated sound levels will result in permanent loss of hearing acuteness, tinnitus, tiredness, stress, or loss of balance and awareness.

Do not exceed recommended speed, pressure, and/or temperature for pump and equipment being used. Do not dead head pump.

Surfaces of engine become extremely hot during operation. Do not touch surfaces of engine during operation, and allow it to cool before storing or servicing. Keep children away.

### CAUTION

- Make certain that the power source conforms to the requirements of your equipment.

### WARNING

Warning denotes that a potential hazard exists and indicates procedures that must be followed exactly to either eliminate or reduce the hazard, and to avoid serious personal injury, or prevent future safety problems with the product.

### DANGER

Danger is used to indicate the presence of a hazard that will result in severe personal injury, death, or property damage if the notice is ignored.

- Prior to servicing, remove spark plug.
- Provide adequate protection in guarding around the moving parts such as shafts and pulleys.
- Disconnect the power before servicing.
- Release all pressure within the system before servicing any component.
- Drain all liquids from the system before servicing.
- Secure the discharge line before starting the pump. An unsecured discharge line may whip, resulting in personal injury and/or property damage.
- Check all hoses for weak or worn condition before each use. Make certain that all connections are tight and secure.
- Periodically inspect the pump and the system components. Perform routine maintenance as required (See Maintenance).
- Protect pump from freezing conditions by draining liquid and pumping a permanent-type automobile antifreeze containing a rust inhibitor through the system, coating the pump interior. A 50% mixture with water is recommended.
- Use only pipe, hose, and hose fittings rated for maximum rated pressure of the pump or the pressure at which the pressure relief valve is set at. Do not use used pipe.
- Do not use these pumps for pumping water or other liquids for human or animal consumption.

## Hazardous Substance Alert

1. Always drain and flush pump before servicing or disassembling for any reason (see instructions).
2. Never store pumps containing hazardous chemicals.
3. Before returning pump for service/repair, drain out all liquids and flush unit with neutralizing liquid. Then, drain

the pump. Attach tag or include written notice certifying that this has been done.

**It is illegal to ship or transport any hazardous chemicals without United States Environmental Protection Agency Licensing.**

### IMPORTANT

**For best possible performance and continuous, satisfactory operation, read these instructions before installing your new pump.** Should service be required, this manual can be a valuable guide. It should be kept near the installation for ready reference.

#### Preliminary to Mounting

Before setting up the pump for operation, check to see that the motor and pump turn freely by hand. If it cannot be turned over by pulling on the recoil starter, open casing to check for obstructions lodged in pump.

#### Basket Strainer

A basket strainer is to be used when transferring solutions that may contain debris and solids which could become lodged in the pump or damage the impeller. Because of the high flow capacity of this pump, unknown debris could be siphoned off the bottom of the tank. Install the strainer on the suction side of the pump whenever possible to avoid pump damage.

### INSTALLATION

#### Location

Place unit as close to water source as possible to minimize suction lift, obtain the best pumping performance, and aid in priming. A typical portable installation is shown in Figure A.

For permanent installation, mount unit on a foundation that will support the weight of the pump and engine and also provide stability while the pump is running. For most permanent installations, it is advisable to bolt unit directly to foundation.

Pump discharge must be oriented vertically. Do not mount the pump in any other orientation or the pump will not adequately prime.

**NOTE:** Settling and/or shifting during operation can cause piping to place excessive strain on the pump and may damage pump case. Set pump on hard level surface. Non-level surfaces may cause the oil sensor in the engine to shut down the unit.

#### Pump Inlet Line

To achieve full capacity from the pump, the inlet line should be at least the same size as the inlet port on the pump. Reducing this line size will restrict the capabilities of the pump. The line must also be free of air leaks. Check all fittings and connections in the suction line for tightness. The

introduction of air may affect the priming and pumping capabilities of the pump. Use good quality suction hose that will not be collapsed by suction. Connect either rigid pipe or flexible suction hose to pump suction as shown in Figure A. If hose is selected, hose must be rated to hold the suction vacuum and prevent collapse while the pump is running. Make the suction line a continuous rise from the water source to the pump. High spots can trap air and also make priming difficult. Make sure all connections are tight and free of air leaks.

Minimum depth for the suction inlet is determined by the diameter of the suction line. See Figure A.

#### Pump Outlet Line

Your pump is equipped with a single port discharge. Select the appropriate size for the application. Install a "T" as shown in Figure A to allow easy priming of the pump without disconnecting the piping, or by using the priming plug on the housing.

**NOTE:** The inlet and discharge plumbing for this system will need to be adequately supported to prevent damage to the pump housing.

Damage due to improperly supported plumbing will not be covered in product warranty.

#### Priming the Pump

#### **CAUTION**

**The pump must not be run dry.**

**Before starting the pump, the pump chamber must be filled with liquid and all discharge lines must be open. The pump must not be run unless it is completely filled with liquid because there is a danger of damaging the mechanical seal, which depends on the liquid for its lubrication.**

#### Strainers

The recommended placement of the strainer for a centrifugal pump is in the pump outlet line. This will eliminate any possible restriction that the strainer could create if it were installed in the inlet line. Ensure that the proper strainer size and screen mesh are used to limit the pressure drop and achieve the best filtration. Line strainers can also be installed in the tank fill line to filter liquid as it is loaded into the tank as well as in the boom lines to further filter the solution prior to the spray tips. Tank baskets can also be used to filter material added through the tank lid.

# Plumbing Diagram - All Models

**NOTE:**

Pump chamber must be filled with liquid in order to prime. Damage to internal components will occur if pump is run dry.

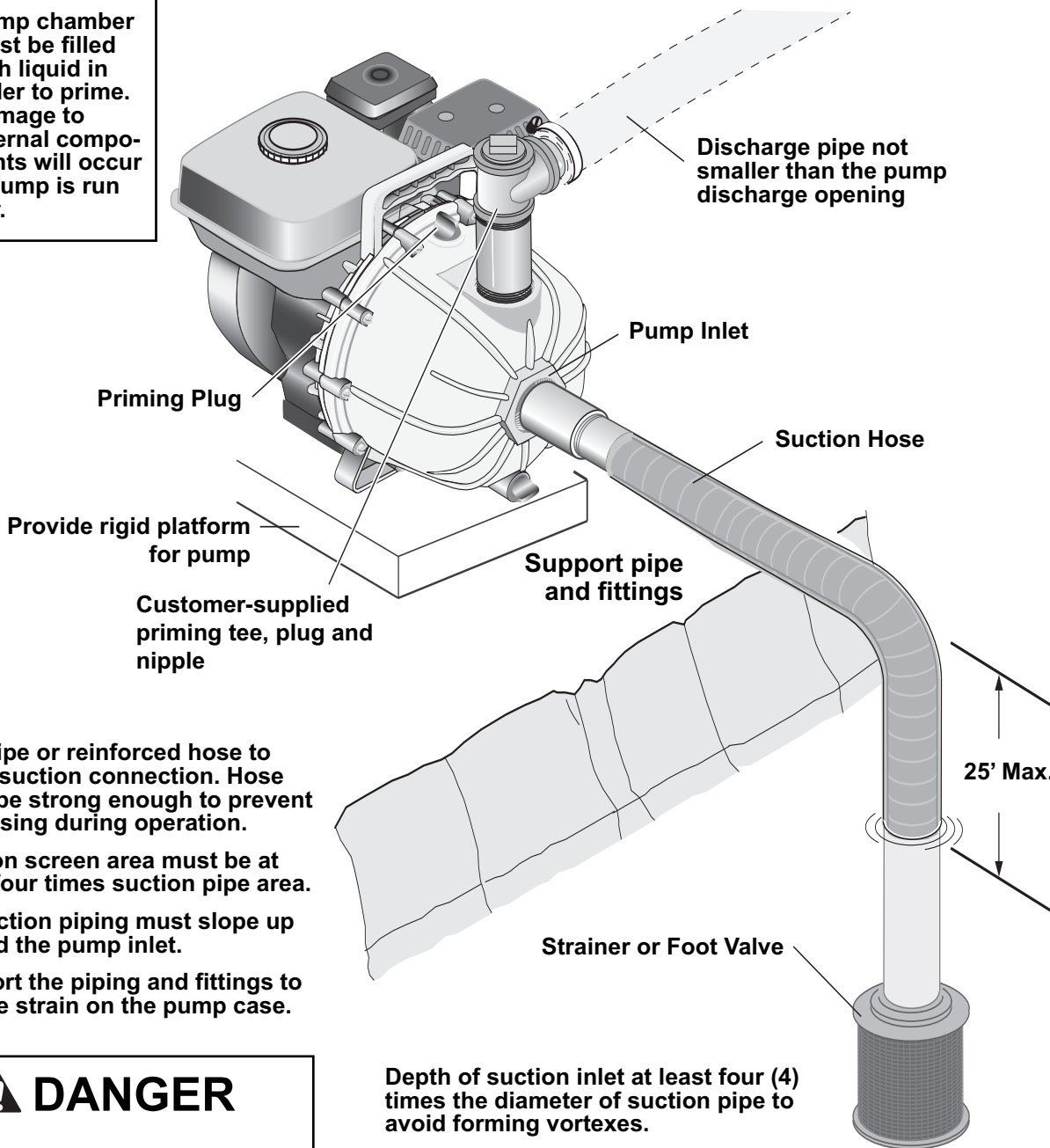

Use pipe or reinforced hose to make suction connection. Hose must be strong enough to prevent collapsing during operation.

Suction screen area must be at least four times suction pipe area.

All suction piping must slope up toward the pump inlet.

Support the piping and fittings to reduce strain on the pump case.

## **⚠ DANGER**

**Hazardous Suction.**

Can trap persons against suction inlet.

Always use strainer on suction hose to prevent entrapment.

If drawing from open pit, pool, tank or pond, make sure it is evacuated prior to operation.

Depth of suction inlet at least four (4) times the diameter of suction pipe to avoid forming vortices.

Example:

3" pipe x 4 = 12" minimum depth

**Figure A**

# Operation and Maintenance - Engine-Driven Pumps

## Models 1543P-90SP, 1543P-130SP, and 1543P-390EHSP

### Preparations Before Starting the Engine

1. Fuel: Check fuel level in tank, and do not over fill. Use fresh, clean automotive fuel. **Note: DO NOT FILL FUEL TANK WHEN ENGINE IS RUNNING.**
2. Engine Oil: Before checking or refilling with engine oil, make sure the engine is stopped and placed on a stable, level surface. Use oil recommended for ambient air temperatures that the engine will be running at. See chart below. Change oil after the first 20 hours and every 100 hours thereafter.

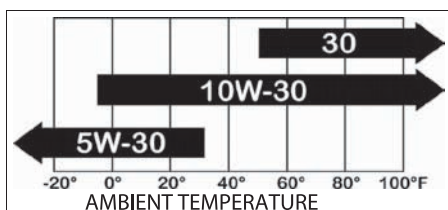

3. Priming Water: **IMPORTANT: PUMP MUST NOT BE RUN DRY.** On self-priming pumps, only the chamber needs to be filled with liquid. The pump must not run unless the priming chamber is completely filled with liquid because there is a danger of damaging the mechanical seal, which depends on the liquid for its lubrication.

Self-priming models can be primed by removing the filler cap located at the top of the pump where the discharge line is mounted to the pump, and filling the priming chamber with liquid. After use, the priming chamber should be flushed and drained to avoid chemical corrosion and damage from freezing. Drain by removing the lower drain plug located at the bottom of the casing.

### Starting the Pump

**IMPORTANT: Before starting engine, be sure the priming chamber is filled with liquid and the discharge hose is secure.**

1. Turn engine switch located by recoil starter to ON position.
2. Turn the fuel cock to ON.
3. Push the throttle lever to a slightly open position.
4. Operation of choke lever.

#### **When engine is cold:**

In cold weather, start engine with choke in fully closed position.

In warm weather, start engine with choke in half-closed position.

#### **When engine is warm:**

Start engine with choke in fully open position.

5. Start engine by pulling recoil starter out quickly and forcefully. Repeat pulling until the engine starts.

### Operation of the Pump

1. Idle the engine for 3 to 5 minutes to warm it up.
2. Open the throttle lever to the upper zone after engine has warmed up.
3. Once the pump has primed, you will note a load on the engine; adjust rpms to proper speed for your pumping application.
4. Do not dead head pump or run dry.

### Stopping the Pump

1. Stop pump for a short time:  
Run engine throttled all the way down (fully to the right). Turn engine switch to OFF position.
2. Stopping pump for storage:  
Turn fuel cock to OFF position instead of turning the engine switch off.  
Let the engine idle for 2 to 3 minutes until fuel in carburetor is depleted and engine stops. If a valve is installed on the discharge hose, you may run pump with valve closed during this procedure.  
**Note: Pump must not be run dry. Make sure there is water in the priming chamber.**

### Storage

1. Drain pump. Flush pump after use.  
One of the most common causes for faulty pump performance is gumming or corrosion inside the pump. Flush the pump and entire system with a solution that will chemically neutralize the liquid pumped. Mix according to the manufacturer's directions. This will dissolve most residues remaining in the pump, leaving the inside of the pump clean and ready for use.
2. Drain all the fuel from the fuel tank, fuel lines, and filter.
3. Store pump in a clean, dry environment.

### Running the Engine

Refer to engine operation section of this manual for starting and operating instructions.

Pump performance varies depending on engine RPM. Refer to engine operation to adjust engine speed.

## MAINTENANCE

### Pump Lubrication

Pump liquid end does not require any grease or oil for lubrication. The mechanical seal is lubricated by water when the pump is operating.



# PUMP ENGINE OPERATION AND MAINTENANCE

## Engine Safety Precautions:

**▲ WARNING** **Fire and explosion hazard.** Gasoline can explode. Store gasoline away from the engine. Add gasoline to the engine only when the engine is off.

**▲ WARNING** **Burn hazard.** Hot surface. The engine gets very hot during operation. Do not touch the engine surfaces. Keep children away. Allow the engine to cool before moving it indoors.

**▲ WARNING** **Deadly fumes.** Carbon monoxide. Never run the engine in an enclosed space. Only use outdoors with plenty of ventilation.

## Engine Operation

Before starting the engine:

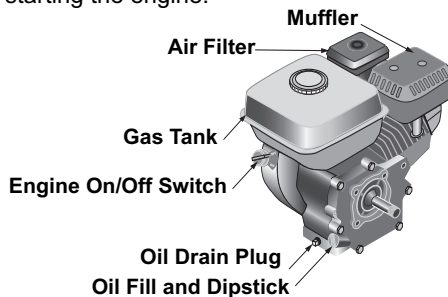

### Check and Fill Oil

The engine is shipped **without oil**. It must be filled before starting the engine.

Fill with oil by removing the fill cap / dipstick. Add oil until the level reaches the bottom of the opening. Check the oil level by pushing the cleaned dipstick into the oil-fill opening. **DO NOT SCREW IT IN.** Remove the dipstick and inspect it. Add oil if needed. Reinstall the cap / dipstick.

Oil capacity is 36 ounces (1.1 liter). #10W-30 oil should be used in normal conditions. Use #40W oil if the engine is to be run in temperatures over 90°F (32°C).

Note that the engine has a low-oil monitoring system. If the oil level drops too low, the system will automatically turn off the engine.

**Add Gasoline --** Fill gas tank with clean, fresh gasoline. This should be unleaded fuel that has an octane rating of 86 or higher.

Do not fill the tank to overflowing. Clean up any spilled gasoline before starting the engine.

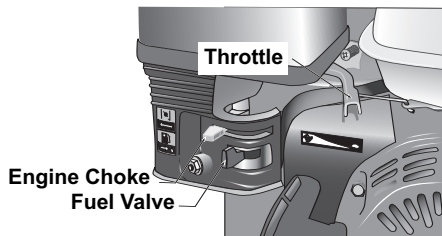

**Open Fuel Valve --** Move the fuel valve to the right to allow fuel to the engine.

**Close Choke --** When starting a cold engine, move the choke control to the left (closed). As the engine warms up, move it towards the right (open). A warm engine should start with the choke open.

**Position Throttle --** Move the throttle (speed control) slightly to the left.

**Turn Engine Switch On --** The engine switch controls the ignition. Turn it to the "ON" position to start the engine. The same control is used to stop the engine.

**Pull Starter --** Pull the handle on the recoil starter. Adjust throttle to desired speed. Move the choke to the right as engine warms.

**Stopping the Engine --** Stop the engine by turning the engine switch to "OFF." Move the fuel valve to "OFF" (left).

## Engine Maintenance

**Air Filter --** The air filter should be checked every month for dust and dirt accumulation. Every 6 months, the filter element should be removed and cleaned. Clean the foam element with detergent and warm water. Squeeze out excess water and let it dry. Before reinstalling the filter element, soak it with engine oil and squeeze out the excess. Reinstall the filter. The engine will smoke upon start-up if too much oil is left in the filter element.

**Oil Level --** The oil level should be checked before each use.

**Oil Change --** The oil should be changed in the first month, and then every 6 months (or 100 hours of operation). To drain the oil, run the engine until warm. Turn off the engine, remove the oil drain plug, and let the the oil drain into a pan. Reinstall the plug and fill with oil. (Capacity: 37 oz. [1.1 L]).

**NOTE:** Dispose of used oil responsibly. **DO NOT** pour it down drains, onto the ground or put it in the trash. Most communities have collection points for used oil.

**Spark Plug --** The spark plug should be checked and cleaned every 6 months or 100 hours. It should be replaced if it is damaged or excessively worn. The spark plug is type BPR6ES (NGK) or equivalent. The plug gap should be 0.030 in. (0.75 mm).

## Engine Troubleshooting

If the engine won't start:

- Check that there is gas in the tank.
- Make sure the fuel valve is "ON" and that the engine switch is "ON."
- Make sure there is enough oil in the engine to reset the low-oil sensor.
- Check that fuel is getting to the carburetor.\*
- Check for spark at the spark plug.\*

\* These checks to be done by persons with small-engine experience.

## Extended Storage

If the pump will be stored for more than a month or two, follow the steps below:

- drain gasoline.
- change oil.
- squirt oil (or a chemical made for storing engines) in the spark plug hole.
- rotate engine slowly until resistance is felt. (This indicates that both valves are closed.)
- install spark plug.
- cover engine.

## Belt/Pulley Drive Installation - Pedestal Pumps - Model 9243P-SP

### Series 9200 Pedestal-Mounted Centrifugal Pumps

#### Mounting Belts and Pulleys

Mount pulleys as close to pump and motor engine shaft bearings as possible. Check alignment with a straight edge as shown in Figure 2. Make sure that belt has proper tension. (Too much tension will cause bearing wear; too little will cause slippage.) See Figure 3. Check with belt and pulley sources for specific recommendation.

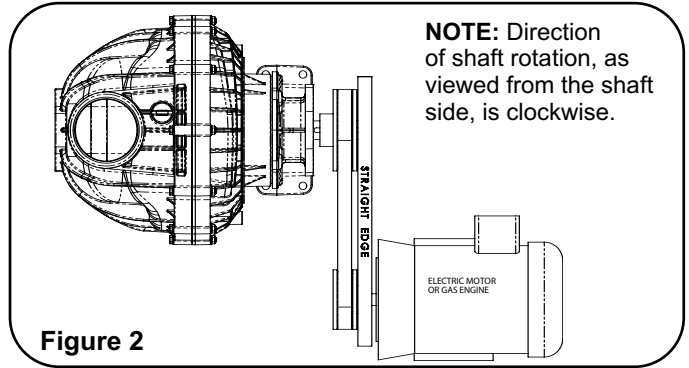

Figure 2

To figure proper diameter of pump pulley, multiply motor/engine rpm by diameter of the motor/engine pulley and divide that figure by desired pump speed.

$$\text{Pump Pulley Size} = \frac{\text{Motor RPM} \times \text{Motor Pulley Size}}{\text{Desired Pump Speed}}$$

Refer to pump performance charts to determine desired speed to obtain desired maximum flow.

**IMPORTANT:** Note that shaft rotation is clockwise as viewed from the shaft. Be sure to drive pump in proper direction.

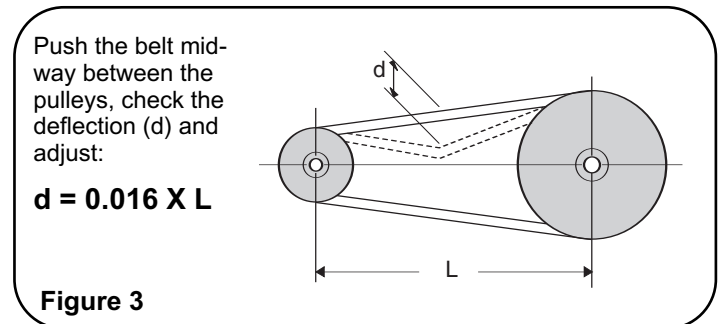

Figure 3

## Direct Drive - Flexible Coupling Installation

### Series 9200 Pedestal-Mounted Centrifugal Pumps

To install couplings, slide coupling ends onto motor or engine and pump shafts as far as possible. Mount engine/motor and pump on base. Shim up pump or power to align shafts. Leave enough room between shaft ends to install center disc. When aligned, slide ends over disc. Select couplings rated twice required horsepower when using motor; three times when using gas engine.

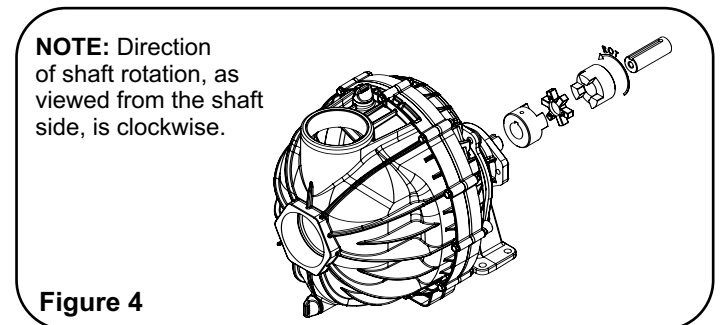

Figure 4



## General Information - Hydraulic Systems - Hydraulic-Driven Pumps

### Models 9343P-GM6-SP and 9343P-GM10-SP

#### Hydraulic Pumps

Hydraulic pumps come in two basic types:

- **Constant displacement** - which will continue to put out its rated flow regardless of pressure, until the relief valve bypasses the flow.
- **Variable displacement** - which will produce only the flow needed by the implement until the total pump output is reached. If less than the full pump output is required, an automatic stroke control mechanism decreases the pump output to maintain a constant pressure and flow. The output varies according to demand.

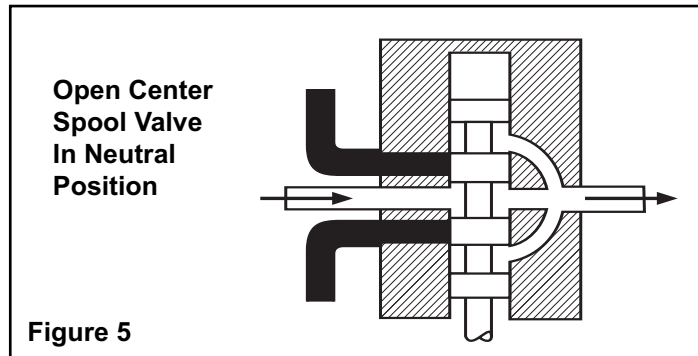

#### Spool Valves

There are two basic types of spool valves used in conjunction with these pumps — Open and Closed Center. In the Open Center Valve (See Figure 5), the flow goes straight through the valve when in the neutral position. This type is used for constant displacement pumps where the flow should never be shut off.

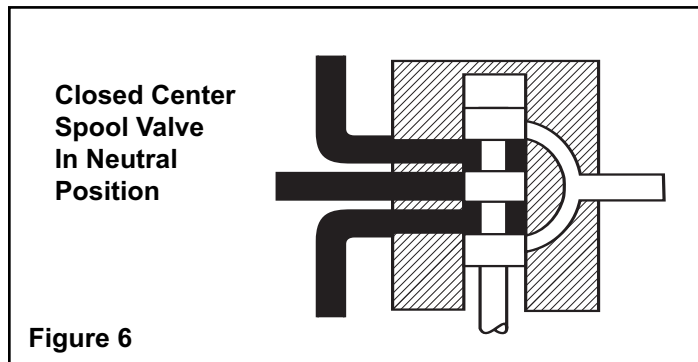

The Closed Center Valve (See Figure 6) is used with variable displacement pumps. The flow is completely shut off in the neutral position, causing the pump stroke to adjust to zero flow. The flow stops, but the pump maintains a static pressure up to the valve.

#### Three Systems

Fitting these components together and installing a motor, we have one of the three types of systems: Open Center, Closed Center (pressure compensated) and Closed Center Load Sensing (flow and pressure compensated).

#### Open Center Systems

In an Open Center System, the hydraulic pump puts out a constant flow. If the pump puts out more oil than the motor can use, a portion of the oil must be bypassed around the motor. When the oil is bypassed around a loop and does no work, the energy put into it by the pump turns into heat. Therefore, the amount of oil bypassed should be kept to a minimum. Use the largest motor possible.

#### Closed Center (Pressure-Compensated) Systems

The Closed Center Pressure-Compensated system has a variable displacement pump which will deliver flow at the necessary rate to maintain a specified pressure. It is desirable to equip implements with a motor of a low flow range that will cause the pump to operate between 1800 and 2100 psi [124 and 145 BAR]. A motor that requires a large volume to obtain the correct implement speed usually causes the hydraulic pump in a closed center system to operate at a lower pressure than desirable. This low pressure results in unnecessary flow and the generation of heat that lowers the lubricating quality of the oil and may damage transmission parts. Use the smallest motor possible.

#### Closed Center Load Sensing Systems (Flow and Pressure-Compensating)

The Closed Center Flow-Compensated System is a variation of the pressure-compensated system, designed primarily for more efficient operation and the generation of less heat. It works on the principle of maintaining a constant pressure drop from the pump to the work port of the selector valve. Any variation in demand at the motor will cause a change in flow. The system senses this change in flow due to the change in pressure drop across the valve and causes the pump to compensate by varying the pump flow. No restrictor is used in the pressure line and no oil is bypassed.

## Hydraulic System Plumbing

### Models 9343P-GM6-SP and 9343P-GM10-SP

#### Preliminary to Mounting

Consult the owners manual to determine the type and capacity of the hydraulic system. Make sure the hydraulic system is recommended to operate with a continuous load. Refer to the Pump Selection Guide to confirm you have the proper pump for your hydraulic system.

Check to see that the pump impeller can be turned by hand. (Turn the shaft clockwise using a deep socket wrench on the impeller nut.) If it cannot be turned, open the pump casing to look for obstructions. Clean out any corrosion build up where the casing fits over the eye of the impeller.

#### Hooking Up the Hydraulic Motor to the Tractor Hydraulic System

Hypro Series 9343P hydraulic motor-driven pumps can be mounted on either the tractor or sprayer. When hooking up, make sure that no dirt or liquid gets into the hydraulic motor. **Keep all hydraulic connections clean.**

Series 9343P pumps utilize gear motor technology for high torque capacity and premium efficiency. Gear motors for 9343P pumps are configured for counterclockwise rotation.

Be sure to connect the hydraulic motor into the system correctly by putting the pressure line to the (IN) Port and return line to the (OUT) Port. For maximum performance, the hydraulic lines should also be at least 3/4" [19 mm] in size.

Standard spool valves, which are found on all tractor hydraulic systems, may cause potentially damaging high peak pressures in the hydraulic system when closed because of abrupt shut-off of oil flow in both the supply and return lines. When shutting off the pump, move the selector to the **FLOAT** position to allow the centrifugal pump to come to a stop gradually.

Hypro gear motors are limited to 35 psi back pressure. Be sure return line is appropriately sized and free of restrictions.

### Hydraulic Motor-Driven Pump Operation

#### 9343P-GM6-SP and 9343P-GM10-SP

#### Open Center Systems

GM6 and GM10 motors are not equipped, from the factory, with a bypass for excess hydraulic flow in a given system. In situations where the hydraulic system has more flow than the motor is rated for (see performance charts), an external bypass must be mounted to the hydraulic lines. **DO NOT** exceed 3600 RPM or 60 psi deadhead with the pump. Failure to restrict the pump to these levels may result in leaks and premature pump failure. To plumb a GM6 or GM10 motor into an open center hydraulic system that is not sized to the 9343P-SP pump requirements, follow these installation instructions:

1. Install a bypass valve in the high pressure hydraulic line. Route bypass flow either to the return line or directly back to tank.
2. Be sure pump housing is full of liquid, and prime transfer pump with all valves open.

3. Open hydraulic bypass all the way. Start hydraulic system and allow oil to circulate for approximately 10 to 15 minutes or until adequately warmed.
4. Close the valve on the discharge side of the transfer pump to achieve deadhead.
5. Gradually close the hydraulic bypass valve until transfer pump deadhead reaches a maximum of 60 psi. **DO NOT** leave the transfer pump at deadhead for longer than 3 minutes. Failure to heed this may result in excessive heat generation inside the pump housing and lead to pump failure.
6. Lock down the system hydraulic bypass valve in this position. **DO NOT** let the pump exceed 60 psi of deadhead pressure. Failure to restrict the pump to these levels may result in leaks and premature failure.

#### Closed Center (Load Sensing) Systems

1. Set the system hydraulic flow control valve for minimum hydraulic oil flow to the remote outlet (Tortoise position).
2. Prime the transfer pump with all valves open.
3. Start the hydraulic system and allow the hydraulic oil to circulate for approximately 10 to 15 minutes or until adequately warmed.
4. Close the valve on the discharge side of the transfer pump to achieve deadhead.
5. Increase system hydraulic flow until transfer pump deadhead reaches a maximum of 60 psi. **DO NOT** leave the transfer pump at deadhead for longer than 3 minutes. Failure to heed this may result in excessive heat generation inside the pump housing and lead to pump failure.
6. Lock down the system hydraulic flow control valve in this position. **DO NOT** let the pump exceed 60 psi of deadhead pressure. Failure to restrict the pump to these levels may result in leaks and premature failure.

## Repair Instructions - All Models

Always flush pump with water or neutralizing agent before servicing.

### PUMP HOUSING DISASSEMBLY

Seal replacement requires that the pump be fully removed from the engine or pedestal. Observe carefully the disassembly process to ensure an easy assembly process. Replace all worn and eroded parts.

1. Remove spark plug wire from the spark plug for safety consideration. Remove the 11 bolts and nuts holding the pump casing to the casing cover using a 10mm socket and a 10mm open end wrench. Pry with screwdriver at bottom of pump casing to break the housing loose. Tap pump casing on the discharge port with a rubber hammer, if necessary. Remove o-ring from back plate. Inspect parts for wear. (See Figure 1.)
2. Remove diffuser by removing the four screws with a 1/4" socket or nut driver. Inspect parts for wear. (See Figure 2.)
3. Remove impeller bolt with a 9/16" wrench. Pry impeller off engine shaft using two flathead screwdrivers. Inspect impeller and ceramic for wear. Ceramic surface must not be scuffed or cracked. To remove ceramic seal from impeller bore, use a small blade screwdriver to wedge the seal out. (See Figure 3.)
4. To remove mechanical seal from back plate, first remove the back plate from the engine by removing the four bolts using a 1/2" wrench. From the engine side of the casing cover, press the mechanical seal out using a piece of 1" PVC pipe (1-5/16" O.D. x 4" long). Inspect parts for wear. (See Figure 4.)
5. Inspect slinger ring on engine shaft for wear. (See Figure 5.)



Fig. 1

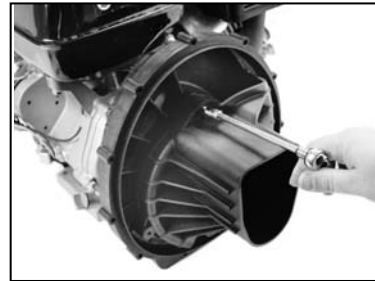

Fig. 2

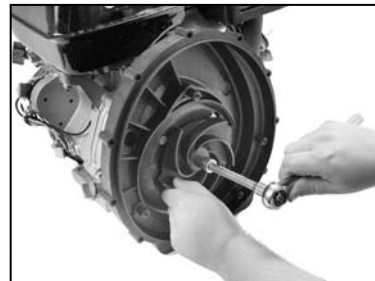

Fig. 3



Fig. 4



Fig. 5

## SEAL REPLACEMENT AND PUMP HOUSING ASSEMBLY

1. Install slinger ring on engine shaft. (See Figure 5.)
2. Lubricate and install the o-ring around back side of metal portion of the seal (See Figure 6). Insert the stationary portion of the new mechanical seal by carefully pushing only on the outer metal ring as you press it into the back plate. Use a tool with 2" OD x 1.78" ID (min.), at least 1" long that fits over the carbon face of the seal, but pushes only on the metal ring to insert the seal. The carbon surface of the seal must be facing you during installation. Be careful to avoid scratching the seal's carbon surface. (See Figure 7.)
3. Apply medium strength (Blue) threadlocker onto the (4) engine mounting bolts and install the pump flange. Tighten the (4) mounting bolts with a 1/2" wrench to a torque of 10 ft.-lbs. (See Figure 8.)
4. Dip the ceramic seal seat in water to lubricate, and carefully press the ceramic ring into the bore of the impeller, seating it squarely on the bottom of the cavity. The glossy, finished side of the ceramic seal must be facing you. **IMPORTANT:** Make sure both seal surfaces are clean and lubricated. Never run seal surfaces dry. (See Figure 9.)
5. Place the key into the key seat of the impeller bore, and install the impeller onto the engine shaft. Apply medium strength (blue) threadlocker onto the impeller bolt; install o-ring into the groove of the impeller, and install and tighten impeller bolt to 10 ft.-lbs. (See Figure 10.)
6. Install volute onto the back plate with four (4) self-tapping screws. Using 1/4" socket, tighten to 24 in.-lbs.
7. Install the flapper onto the pump volute with the flat side of the flapper facing forward.
8. Install the pump casing onto the back plate and o-ring, and secure with the 11 bolts, nuts and washers, using a 10mm socket and wrench. Torque the bolts to 45 in.-lbs.
9. Once assembly is complete, rotate the pump shaft, or pull on the engine recoil starter with engine switch in the "OFF" position to verify that the impeller rotates smoothly without catching. Connect spark plug wire. Assembly and inspection is now complete.



Fig. 6

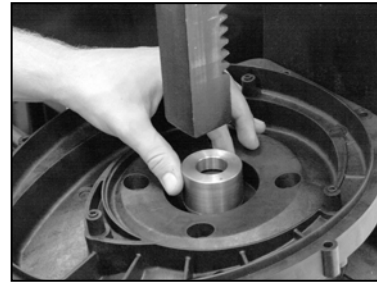

Fig. 7

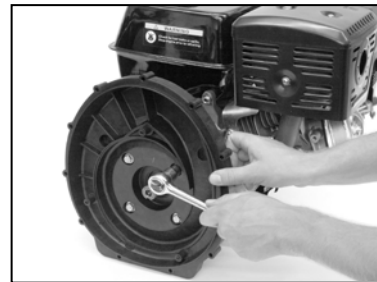

Fig. 8



Fig. 9

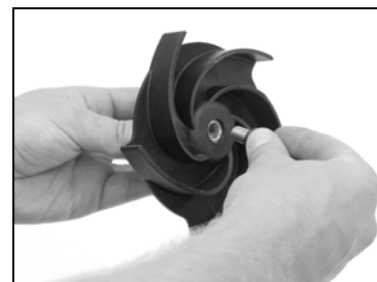

Fig. 10

## Pump Shaft and Bearing Assembly Removal and Replacement

1. While the pump is disassembled (see the Pump Housing Disassembly section), the driven pulley on the pump shaft must be removed. Remove the large retainer ring in pump bearing bore on the pulley side of housing. Press out the shaft and bearing assembly from the pump side using an arbor press.
2. Bearings must be pressed off each end of shaft and replaced in the same manner. **NOTE:** Shaft diameter between bearings is larger.
3. For reassembly, reverse the order of instructions.

## Troubleshooting Guide

SYMPTOM	PROBABLE CAUSE															
	ENGINE				PUMP						SYSTEM					
	A	B	C	D	E	F	G	H	I	J	K	L	M	N	O	P
No water delivered					X	X	X				X	X	X			X
Not enough water delivered	X						X	X			X	X	X			X
Not enough pressure	X						X	X			X	X	X			
Engine heats excessively		X	X					X	X	X		X		X		
Abnormal noise and/or vibration				X	X		X			X		X	X	X		
Pump works for a while, then stops				X			X			X			X		X	X

CAUSE	CORRECTIVE ACTION
<b>1. ENGINE</b>	
A. Speed too low.	Refer to engine section.
B. Rotating and/or reciprocating parts drag.	Refer to engine section.
C. Speed too high.	Maximum engine speed not to exceed engine manufacturer's recommendation.
D. Loose or broken parts.	Refer to engine section.
<b>2. PUMP</b>	
E. Not primed.	Reprime, inspect suction system for air leaks, and/or check assembly.
F. Pump takes too long to prime.	Check for air leaks or defective check valve.
G. Flow through pump completely or partially blocked.	Locate and remove obstruction. Attach strainer.
H. Internal leakage.	Check clearances between face of vanes and case. Should not exceed 1/32".
I. Rotating parts drag.	Inspect. Repair.
J. Loose or broken parts.	Inspect. Repair.
<b>3. SYSTEM</b>	
K. Pressure required by system at design flow rate exceeds pressure rating of pump.	Compare pump pressure and flow rate against pump performance chart. Reduce system pressure requirement. Increase pressure capability of pump.
L. Obstruction in suction piping.	Locate and remove obstruction. Attach strainer.
M. Suction lift too high.	Check with gauge or measure vertical distance between water surface and center line of pump, allowing for friction loss in suction pipe. Reduce rate of flow to obtain desired lift. Refer to pump performance chart.
N. Discharge head too low.	Decrease rate of flow.
O. Suction inlet not immersed deep enough.	Refer to "Installation".
P. Leaky suction line or connection admitting air.	Repair or replace suction line. Tighten connections.

# Pump Performance - 1543P Series

1543P Pump Performance - Standard

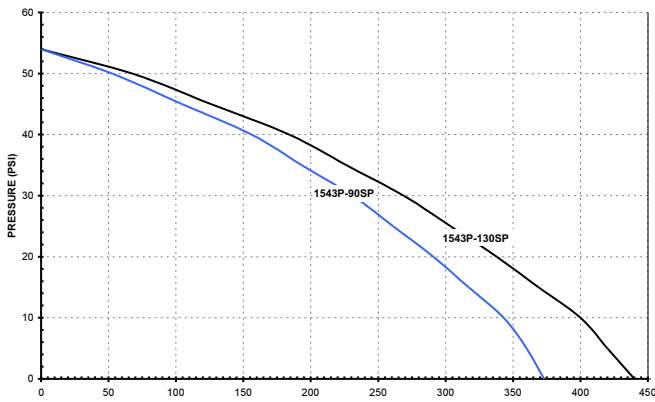

1543P Pump Performance - Metric

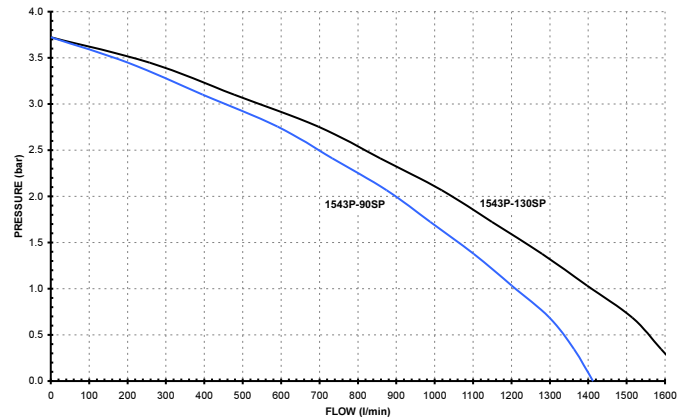

**Note:** 9.0 HP versions not recommended for specific gravities above 1.0.

PERFORMANCE	Feet	0	12	23	35	46	58	69	81	92	104	116	125
	PSI	0	5	10	15	20	25	30	35	40	45	50	54
1543P-90SP	GPM	373	360	343	317	291	261	231	194	156	105	53	0
1543P-130SP	GPM	440	420	400	369	338	304	269	227	184	126	68	0

PERFORMANCE	m	0.0	3.5	7.0	10.6	14.1	17.6	21.1	24.6	28.2	31.7	35.2	38.0
	bar	0.0	0.3	0.7	1.0	1.4	1.7	2.1	2.4	2.8	3.1	3.4	3.7
1543P-90SP	l/min	1412	1363	1298	1200	1102	988	874	732	591	396	201	0
1543P-130SP	l/min	1666	1590	1514	1397	1279	1149	1018	857	697	477	257	0

## Dimensional Drawings - 1543P Series

DIMENSION	1543P-90SP 1543P-90ESP	1543P-130SP 1543P-130ESP	1543P-390EHSP
A	11.5 [292]	12.0 [305]	12.0 [305]
B	23.0 [584]	24.0 [610]	24.0 [610]
C	16.25 [413]	17.25 [438]	17.25 [438]
D	6.38 [162]	7.12 [181]	7.12 [181]
E	2.54 [65]	2.75 [70]	2.75 [70]
F	3.82 [97]	4.06 [103]	4.06 [103]

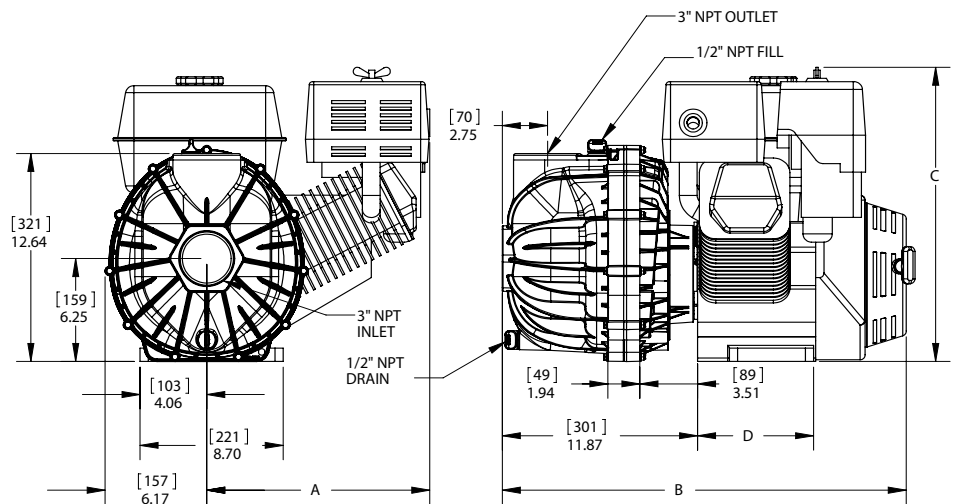

MODEL NUMBER	DESCRIPTION
1543P-90SP	PUMP, 9HP POWERPRO ENGINE, MANUAL START
1543P-90ESP	PUMP, 9HP POWERPRO ENGINE, ELECTRIC START
1543P-130SP	PUMP, 13HP POWERPRO ENGINE, MANUAL START
1543P-130ESP	PUMP, 13HP POWERPRO ENGINE, ELECTRIC START
1543P-390EHSP	PUMP, GX390 HONDA ENGINE, ELECTRIC START

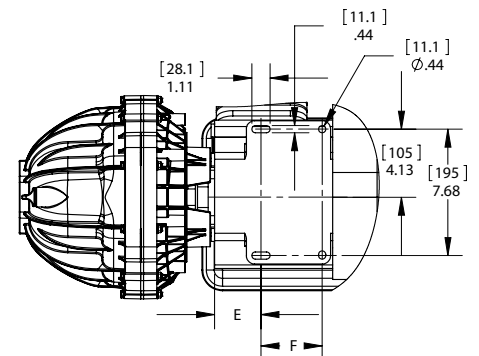



# Pump Performance - 9243P Series

9243P-SP Pump Performance - Standard

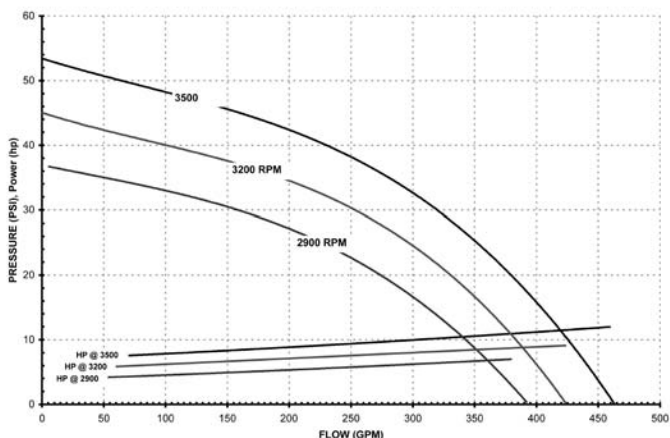

9243P-SP Pump Performance - Metric

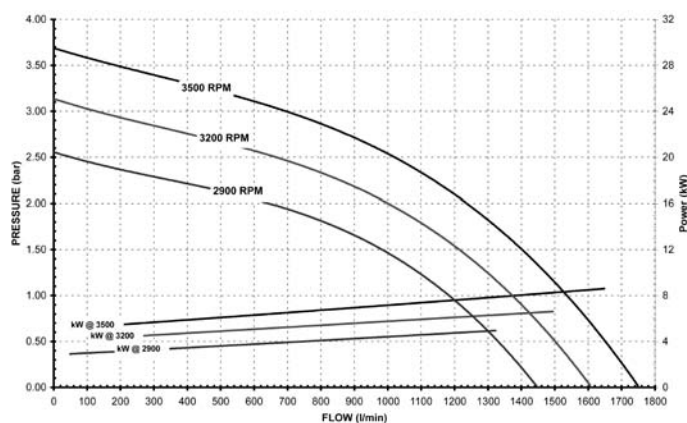

9243P-SP PERFORMANCE	Feet	0	12	23	35	46	58	69	81	92	104	116
	PSI	0	5	10	15	20	25	30	35	40	45	50
2900 RPM	GPM	380	358	342	312	275	224	160	50			
	HP	7.1	6.8	6.5	6.3	6.0	5.6	5.0	4.2			
3200 RPM	GPM	424	405	384	359	331	297	251	193	103	0	
	HP	9.1	8.9	8.7	8.5	8.3	8.0	7.5	7.0	6.2	5.3	
3500 RPM	GPM	460	445	425	404	379	353	321	280	227	159	70
	HP	12.2	11.8	11.4	11.1	10.9	10.6	10.2	9.8	9.2	8.5	7.5

9243P-SP PERFORMANCE	m	5.1	10.2	12.8	15.3	17.9	20.4	23.0	25.5	28.1	30.6	33.2	35.7
	bar	0.50	1.00	1.25	1.50	1.75	2.00	2.25	2.50	2.75	3.00	3.25	3.50
2900 RPM	l/min	1325	1193	1097	980	830	637	376	46				
	kW	5.0	4.7	4.6	4.4	4.1	3.8	3.4	2.9				
3200 RPM	l/min	1497	1378	1301	1215	1118	996	853	660	403	154		
	Kw	6.6	6.4	6.3	6.1	6.0	5.7	5.5	5.2	4.7	4.3		
3500 RPM	l/min	1650	1537	1471	1403	1328	1242	1139	1016	866	685	467	208
	Kw	8.7	8.3	8.2	8.0	7.9	7.7	7.5	7.2	6.9	6.5	6.0	5.5

# Dimensional Drawings - 9243P Series

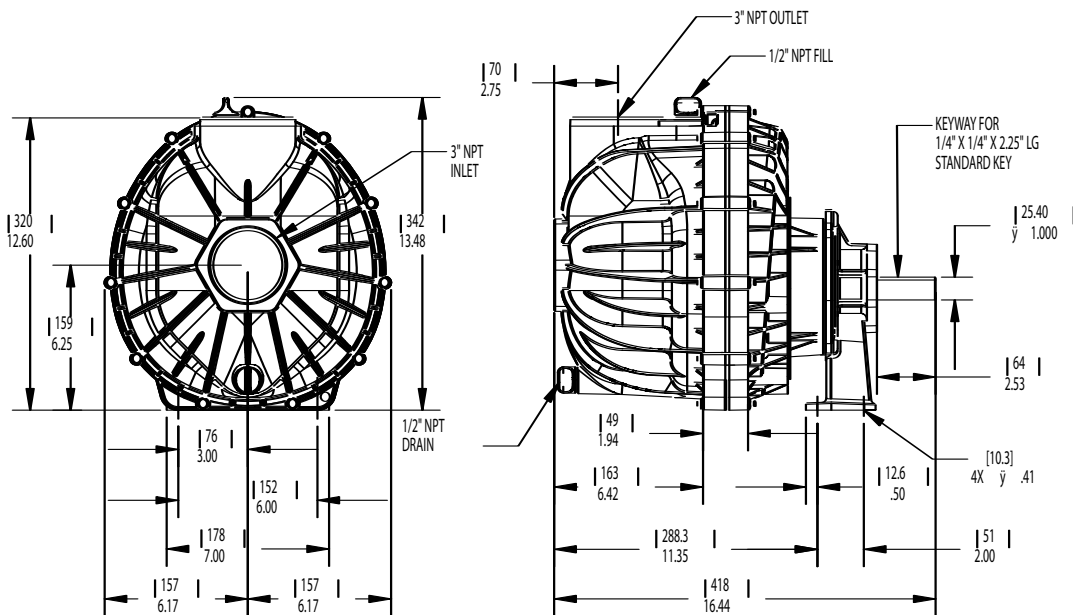

# Pump Performance - 9343P Series

### 9343P-GM6-SP Pump Performance - Standard

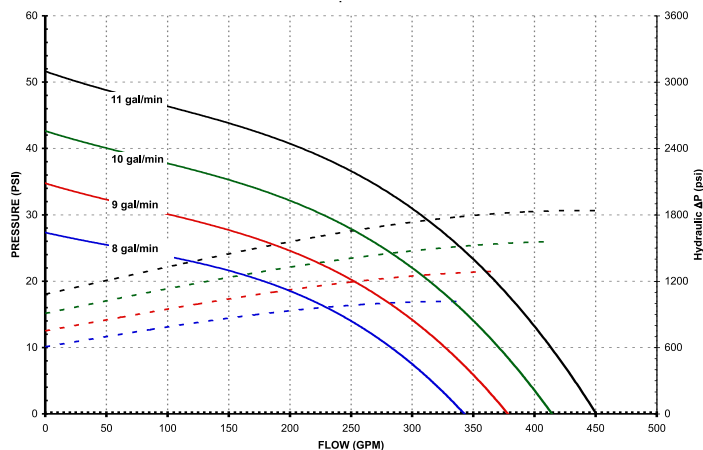

### 9343P-GM6-SP Pump Performance - Metric

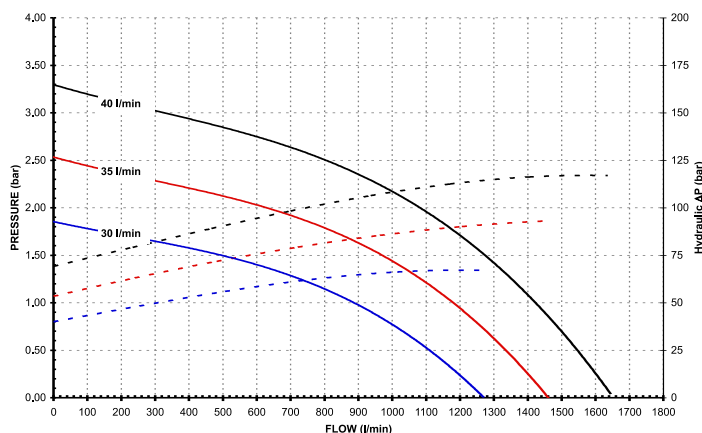

### 9343P-GM10-SP Pump Performance - Standard

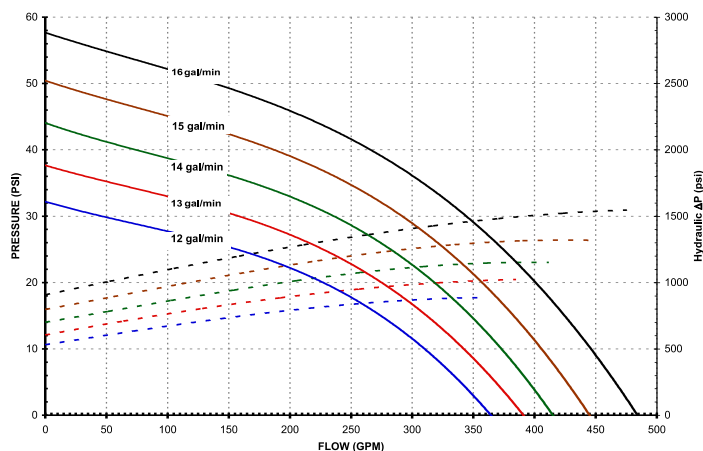

### 9343P-GM10-SP Pump Performance - Metric

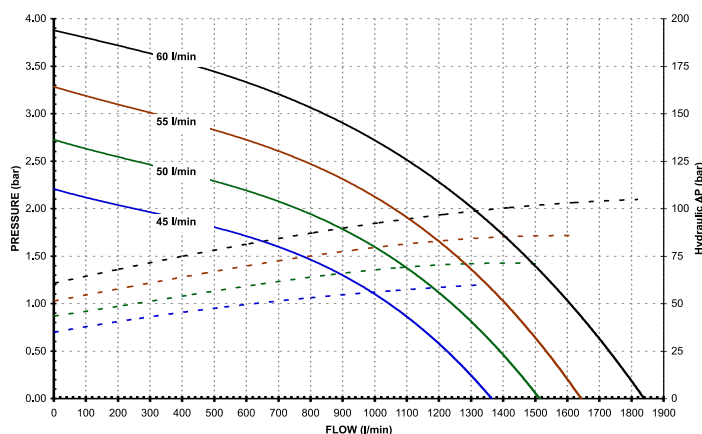

9343P-GM6-SP PERFORMANCE	Feet	0	12	23	35	46	58	69	81	92	104	116	127
	PSI	0	5	10	15	20	25	30	35	40	45	50	55
8 gal/min	GPM	342	316	284	240	176	67						
9 gal/min	GPM	378	355	327	294	252	194	103					
10 gal/min	GPM	414	394	371	345	314	276	227	155	52			
11 gal/min	GPM	450	433	414	392	368	340	307	265	210	128	28	

9343P-GM6-SP PERFORMANCE	m	5.1	10.2	12.8	15.3	17.9	20.4	23.0	25.5	28.1	30.6	33.2	35.7
	bar	0.50	1.00	1.25	1.50	1.75	2.00	2.25	2.50	2.75	3.00	3.25	3.50
30 l/min	l/min	1110	885	730	495	145							
35 l/min	l/min	1335	1180	1085	970	825	630	345	35				
40 l/min	l/min	1545	1425	1355	1270	1185	1080	960	805	600	325	45	

9343P-GM10-SP PERFORMANCE	Feet	0	12	23	35	46	58	69	81	92	104	116	127
	PSI	0	5	10	15	20	25	30	35	40	45	50	55
12 gal/min	GPM	364	340	310	274	227	157	46					
13 gal/min	GPM	391	368	342	312	275	227	158	55				
14 gal/min	GPM	415	395	373	348	318	282	236	170	74			
15 gal/min	GPM	445	426	406	383	357	327	292	247	187	102	7	
16 gal/min	GPM	484	466	446	425	401	374	344	309	266	211	139	47

9343P-GM10-SP PERFORMANCE	m	5.1	10.2	12.8	15.3	17.9	20.4	23.0	25.5	28.1	30.6	33.2	35.7
	bar	0.50	1.00	1.25	1.50	1.75	2.00	2.25	2.50	2.75	3.00	3.25	3.50
45 l/min	l/min	1225	1045	925	775	560	250						
50 l/min	l/min	1390	1240	1150	1045	920	760	540	255				
55 l/min	l/min	1535	1405	1335	1255	1165	1060	935	780	575	310	35	
60 l/min	l/min	1730	1610	1540	1470	1390	1305	1215	1105	985	840	665	445

# Dimensional Drawings - 9343P Series

Model 9343P-GM6-SP

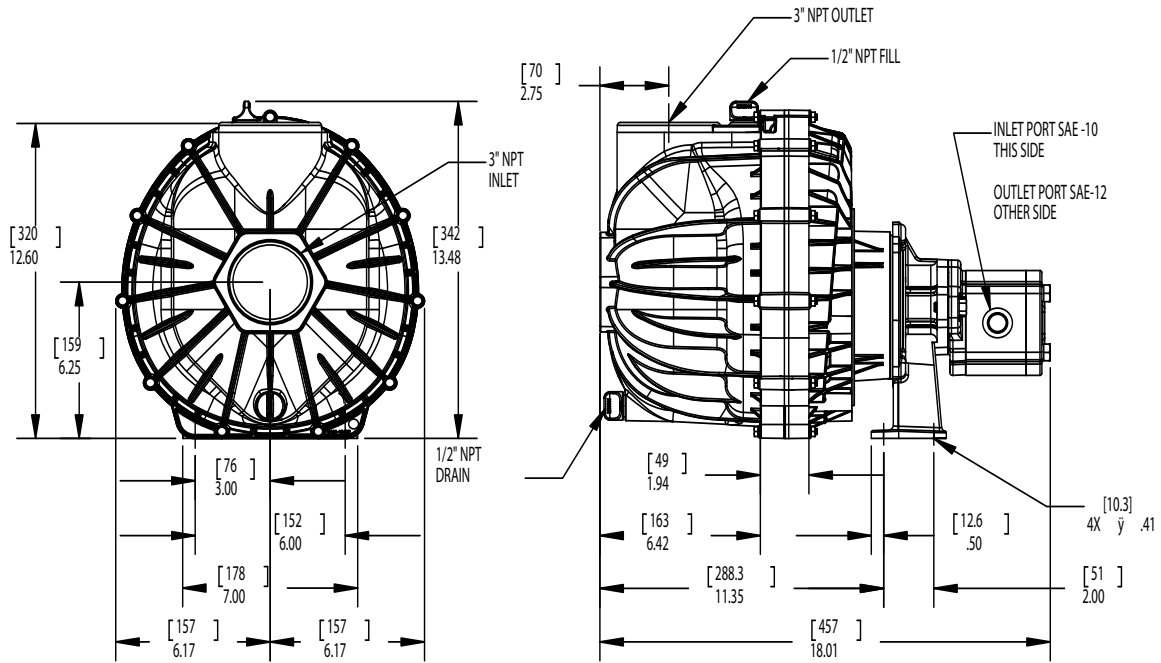

Model 9343P-GM10-SP

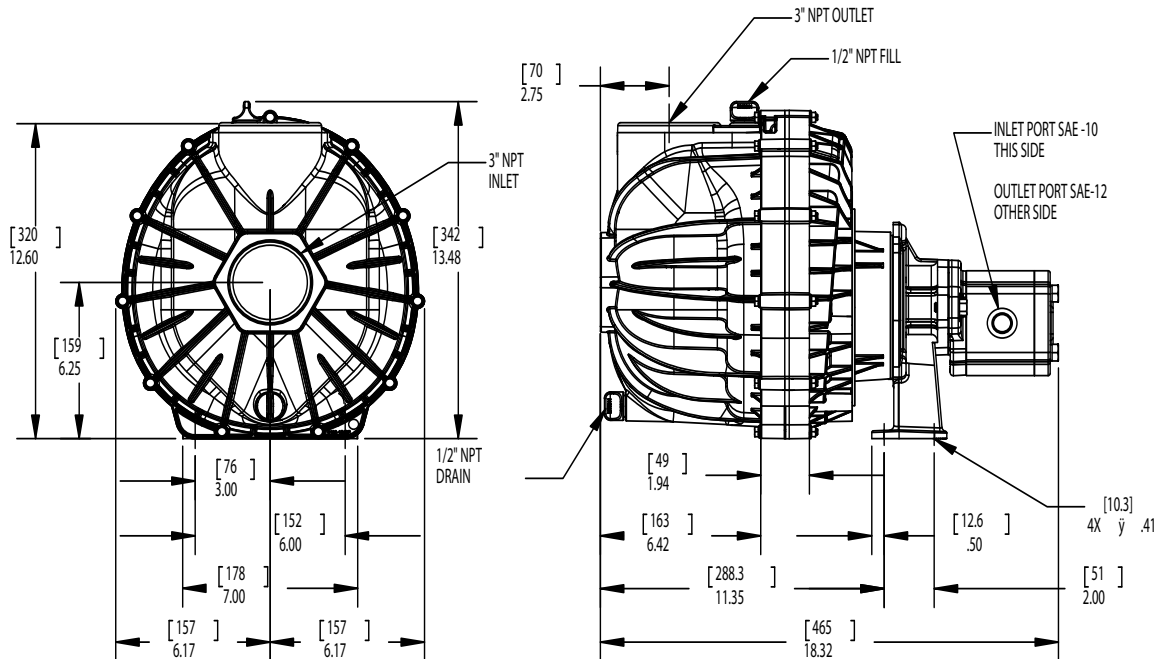

# 1543P-90SP, 1543P-90ESP, 1543P-130SP, 1543P-130ESP, and 1543P-390EHSP Gas Engine-Driven, Self-priming, Polypropylene Transfer Pumps

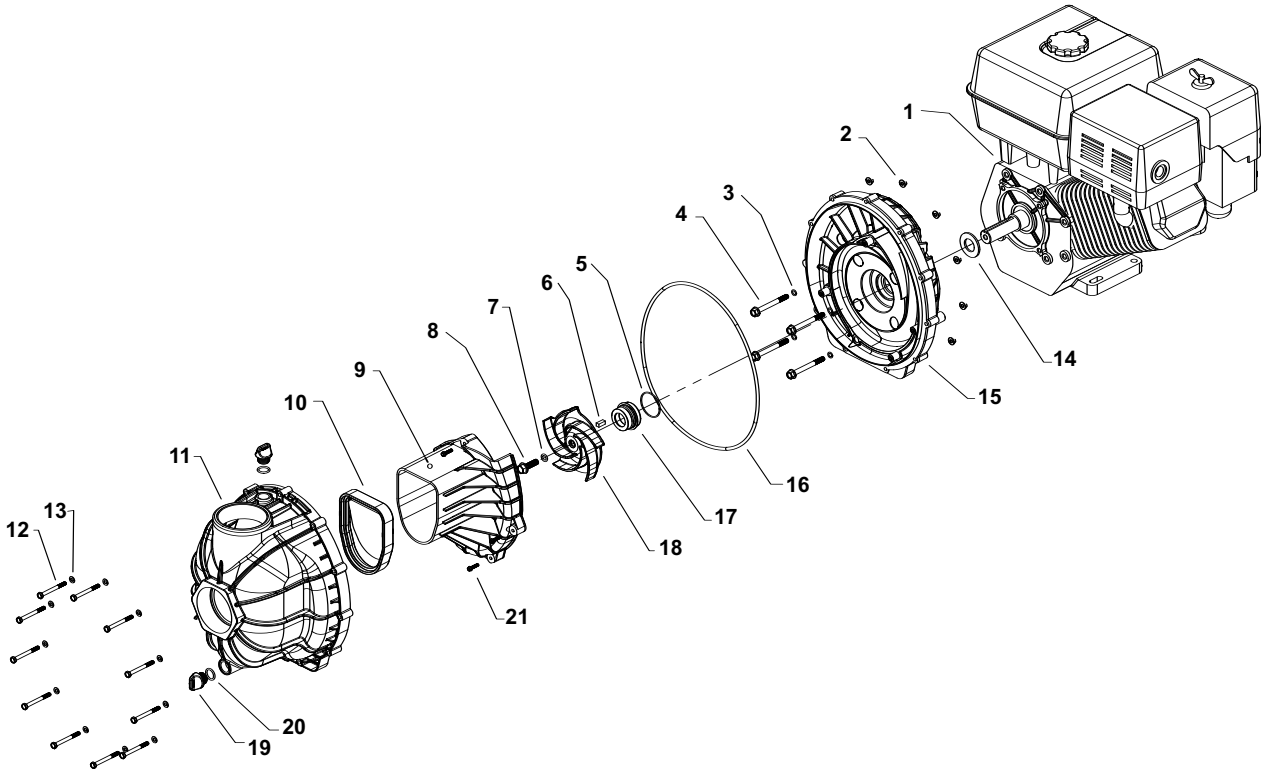

Seal Repair Kit 3430-0757 contains:  
 (4) Ref. 3 O-ring, (1) Ref. 5 Mechanical Seal O-ring, (1) Ref. 17 Mechanical Seal, (1) Ref. 7 Impeller O-ring, (1) Ref. 10 Flapper, and (1) Ref. 16 Body O-ring.

Shim Kit 3430-0758 contains:  
 (3) 1430-0034 Impeller Shim (not shown)  
 (3) 1430-0035 Engine Shim (not shown)  
 May be required on engines other than PowerPro™

Ref #	Torque Spec.
#4	10 ft.-lbs.
#8	10 ft.-lbs.
#12	45 in.-lbs.
#21	24 in.-lbs.

Pump Head Kit 3430-0692 Includes all items less the engine (Ref. 1).

Ref. No.	Qty.	Part No.	Description
1	1	2543-0047	9 HP PowerPro™ Engine, Manual Start
1	1	2543-0056	9 HP PowerPro™ Engine, Electric Start
1A	1	2543-0048	13 HP PowerPro™ Engine, Manual Start
1A	1	2543-0049	13 HP PowerPro™ Engine, Electric Start
1B	1	2541-0057	13 HP Honda Engine, Electric Start
2	11	2250-0087	Hex Flange Nut
3	4	1723-0149	O-ring
4	4	2210-0182	Hex Flange Bolt
5	1	1723-0148	O-ring
6	1	1610-0069	Key (square)
7	1	1723-0142	O-ring
8	1	2210-0181	Hex Flange Bolt
9	1	0150-1543P	Pump Volute

Ref. No.	Qty.	Part No.	Description
10	1	1700-0232	Flapper Valve
11	1	0100-1543P	Pump Housing
12	11	2210-0141	Hex Head Cap Screw
13	11	2270-0115	Flat Washer
14	1	1410-0091	Slinger Ring
15	1	0750-1543P	Back Plate
16	1	1723-0146	O-ring
17	1	2120-0055	Mechanical Seal
18	1	0400-1543P	Impeller
19	2	2404-0350P	Fill/Drain Plug
20	2	1720-0230	O-ring
21	4	2210-0183	Hex Washer Head Screw

## 9243P-SP Pedestal, Self-priming, Polypropylene Transfer Pumps

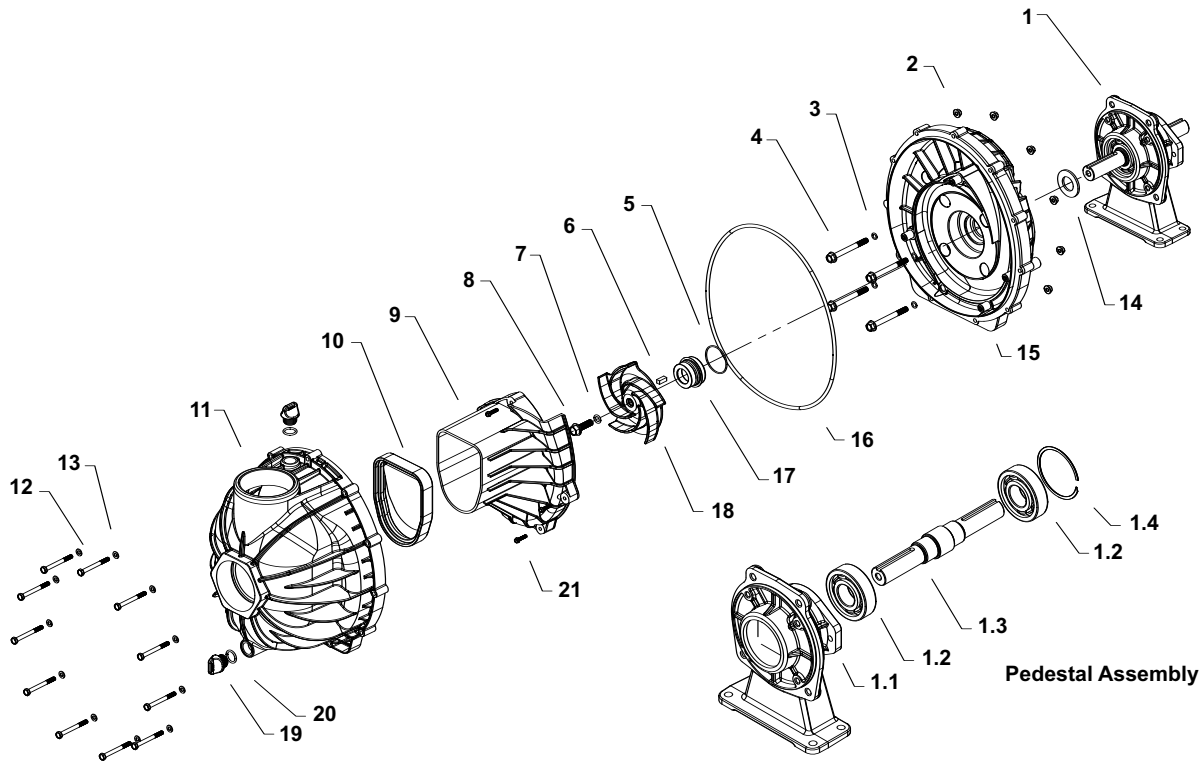

Seal Repair Kit 3430-0757 contains:

(4) Ref. 3 O-ring, (1) Ref. 5 Mechanical Seal O-ring, (1) Ref. 17 Mechanical Seal, (1) Ref. 7 Impeller O-ring, (1) Ref. 10 Flapper, and (1) Ref. 16 Body O-ring.

Pedestal Assembly 0751-9243A contains:

(1) Ref. 1.1 Pedestal, (2) Ref. 1.2 Ball Bearing, (1) Ref. 1.3 Pump Shaft, and (1) Ref. 1.4 Snap Ring.

**Ref # Torque Spec.**

#4 10 ft.-lbs.  
#8 10 ft.-lbs.  
#12 45 in.-lbs.  
#21 24 in.-lbs.

Pump Head Kit 3430-0692 Includes all items less the pedestal (Ref. 1).

Ref. No.	Qty.	Part No.	Description
1	1	0751-9243A	Pedestal Assembly
2	11	2250-0087	Hex Flange Nut
3	4	1723-0149	O-ring
4	4	2210-0182	Hex Flange Bolt
5	1	1723-0148	O-ring
6	1	1610-0069	Key (Square)
7	1	1723-0142	O-ring
8	1	2210-0181	Hex Flange Bolt
9	1	0150-1543P	Pump Volute
10	1	1700-0232	Flapper Valve
11	1	0100-1543P	Pump Housing

Ref. No.	Qty.	Part No.	Description
12	11	2210-0141	Hex Head Cap Screw
13	11	2270-0115	Flat Washer
14	1	1410-0091	Slinger Ring
15	1	0750-1543P	Back Plate
16	1	1723-0146	O-ring
17	1	2120-0055	Mechanical Seal
18	1	0400-1543P	Impeller
19	2	2404-0350P	Fill/Drain Plug
20	2	1720-0230	O-ring
21	4	2210-0183	Hex Washer Head Screw

## Limited Warranty on Hypro/SHURflo Agricultural Pumps & Accessories

Hypro/SHURflo (hereafter, "Hypro") agricultural products are warranted to be free of defects in material and workmanship under normal use for the time periods listed below, with proof of purchase.

- Pumps: one (1) year from the date of manufacture, or one (1) year of use. This limited warranty will not exceed two (2) years, in any event.
- Accessories: ninety (90) days of use.

This limited warranty will not apply to products that were improperly installed, misapplied, damaged, altered, or incompatible with fluids or components not manufactured by Hypro. All warranty considerations are governed by Hypro's written return policy.

Hypro's obligation under this limited warranty policy is limited to the repair or replacement of the product. All returns will be tested per Hypro's factory criteria. Products found not defective (under the terms of this limited warranty) are subject to charges paid by the returnee for the testing and packaging of "tested good" non-warranty returns.

No credit or labor allowances will be given for products returned as defective. Warranty replacement will be shipped on a freight allowed basis. Hypro reserves the right to choose the method of transportation.

This limited warranty is in lieu of all other warranties, expressed or implied, and no other person is authorized to give any other warranty or assume obligation or liability on Hypro's behalf. Hypro shall not be liable for any labor, damage or other expense, nor shall Hypro be liable for any indirect, incidental or consequential damages of any kind incurred by the reason of the use or sale of any defective product. This limited warranty covers agricultural products distributed within the United States of America. Other world market areas should consult with the actual distributor for any deviation from this document.

### Return Procedures

All products must be flushed of any chemical (ref. OSHA section 1910.1200 (d) (e) (f) (g) (h)) and hazardous chemicals must be labeled/tagged before being shipped\* to Hypro for service or warranty consideration. Hypro reserves the right to request a Material Safety Data Sheet from the returnee for any pump/product it deems necessary. Hypro reserves the right to "disposition as scrap" products returned which contain unknown fluids. Hypro reserves the right to charge the returnee for any and all costs incurred for chemical testing, and proper disposal of components containing unknown fluids. Hypro requests this in order to protect the environment and personnel from the hazards of handling unknown fluids.

Be prepared to give Hypro full details of the problem, including the model number, date of purchase, and from whom you purchased your product. Hypro may request additional information, and may require a sketch to illustrate the problem.

**Contact Hypro Service Department at 800-468-3428 to receive a Return Merchandise Authorization number (RMA#).**

Returns are to be shipped with the RMA number clearly marked on the outside of the package. Hypro shall not be liable for freight damage incurred during shipping. Please package all returns carefully. All products returned for warranty work should be sent **shipping charges prepaid** to:

HYPRO  
Attention: Service Department  
375 Fifth Avenue NW  
New Brighton, MN 55112

For technical or application assistance, call the **Hypro Technical/Application number: 800-445-8360**. To obtain service or warranty assistance, call the **Hypro Service and Warranty number: 800-468-3428**; or send a fax to the **Hypro Service and Warranty FAX: 651-766-6618**.

\*Carriers, including U.S.P.S., airlines, UPS, ground freight, etc., require specific identification of any hazardous material being shipped. Failure to do so may result in a substantial fine and/or prison term. Check with your shipping company for specific instructions.

