

## SF-1100 Parts Kits List / Parts Drawing

| Ref. No. | Kit Part No. | Description                                |
|----------|--------------|--|
| 1        | 94-718-00    | Motor Assembly Kit                         |
| 2        | 94-719-00    | Diaphragm/Lower Housing/Drive Assembly Kit |
| 3a       | 94-720-00    | Valve Housing Assembly Kit (EPDM)          |
| 3b       | 94-720-05    | Valve Housing Assembly Kit (Viton)         |
| 4        | 94-721-00    | Upper Housing Assembly Kit                 |

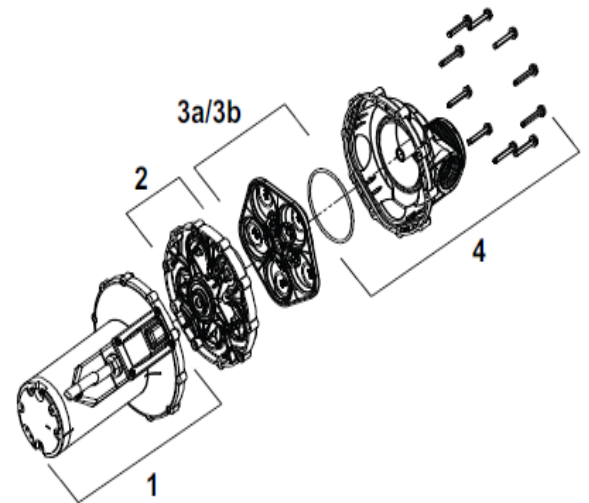

## Mini-Bulk Pump & Flow Meter Kits

### Motor Assembly Kit (Part# 94-718-00)



The 94-718-00 is the motor assembly used in any SF-1100 Series Pump.

**The motor assembly kit includes:**

- 12 VDC motor with 20 ft. cable, alligator clips & inline fuse
- Integrated pump lower housing
- Built-in on-off switch

### Valve Housing Kits



The replacement valve housings include a complete, fully-assembled valve housing with o-ring seal ready for installation. Available with EPDM or Viton valves.

**Manufacturer recommends replacing the o-ring seal whenever the pump has been taken apart.**

#### Order Information

| Part#     | Description   |
|-----------|---------------|
| 94-720-00 | EPDM valves   |
| 94-720-05 | Viton® valves |

### Diaphragm/Lower Housing/Drive Assembly Kit (Part# 94-719-00)



The 94-719-00 is a replacement Santoprene® diaphragm/lower housing/drive assembly ready for installation.

### Pump Housing Kit (Part# 94-721-00)



The 94-721-00 is a replacement polypropylene upper housing which includes the o-ring seal and pump head screws.

**Manufacturer recommends replacing the o-ring seal whenever the pump has been taken apart.**

### FM-1100 Series Meter Electronics Kit

(Part# 94-732-00)



The 94-732-00 Flow Meter Electronics Kit includes the front cover assembly and the electronic display including o-ring and batteries. The electronics kit will fit both the pump-mounted and inline meters.

### FM-1100 Series Meter Nutating Chamber Assembly Kit

(Part# 94-734-00)



The 94-734-00 is a replacement chamber assembly which includes the o-ring seal. The nutating chamber assembly kit will fit both the pump-mounted and inline meters.

### Discharge Hose Kit

(Part# 94-717-00)



The 94-717-00 is a replacement 1-in. NPT x 12 ft. EPDM hose.

### Recirculation Lid Kit

(Part# 94-724-00)



The 94-724-00 is a replacement lid for the Mini-Bulk Chemical Recirculation system.

### Recirculation System Return Hose Kit

(Part# 94-737-00)



The Recirculation System Return Hose Kit includes the return hose and two hose clamps.

### FM-1100 Series Meter Housing Seal Cover Kit

(Part# 94-733-00)



The 94-733-00 Flow Meter Housing Seal Cover Kit includes the seal cover, o-ring and screws. The flow meter housing seal cover will fit both the pump-mounted and inline meters.

### FM-1100 Series Meter Housing Kits



Replacement meter housings for pump-mounted or inline flow meters.

| Part#     | Description                                       |
|-----------|---|
| 94-735-00 | Replacement 90° meter housing with O-ring seal    |
| 94-736-00 | Replacement inline meter housing with O-ring seal |

### Alligator Clips/Fuse Kit

(Part# 94-723-00)



The 94-723-00 is a replacement set of red and black alligator clips, including a fuse holder.

### Recirculation Cap Kit

(Part# 94-725-00)



The 94-725-00 is a replacement cap for the Mini-Bulk Chemical Recirculation system.

### Elbow/Valve/Coupling Kit

(Part# 94-738-00)



The 94-738-00 is a replacement elbow/valve/coupling assembly, which includes a 1-in. street elbow, 1-in. ball valve and a 1-in. bayonet tank coupling.

# Installation, Operation, Repair and Parts Manual

## Description



**Mini-Bulk Chemical Transfer System**



**Mini-Bulk Stand-Alone Pumps**

| Part#       | Description  |
|-------------|--|
| SF-1100-REC | Chemical Transfer Pump with 12 VDC motor, 20 ft. Cable, alligator clips & inline fuse (Part # SF-1100), inline electronic flow meter (Part # FM-1100i), 1-in. NPT x 12 ft. EPDM discharge hose with ball valve/spout, 3-way valve, tubing and fittings to allow tank recirculation |

| Part#        | Valves | Motor   |
|--------------|--------|---------|
| SF-1100      | EPDM   | 12 VDC  |
| SF-1100-110V | EPDM   | 110 VAC |
| SF-1105      | Viton® | 12 VDC  |



**Ag Runner**



**Electronic Flow Meters**

| Part#           | Description  | Flow Meter Type        |
|-----------------|--|------------------------|
| SF-1100-PTS     | Chemical Transfer Pump with 12 VDC motor, 20 ft. Cable, alligator clips and inline fuse (Part # SF-1100), electronic flow meter, 1-in. NPT x 12 ft. EPDM discharge hose with ball valve/spout, and 1-in. NPT x 12 ft. EPDM inlet hose with 1-in. elbow/ball valve/fitting assembly with locking cam arms | Pump-mounted (FM-1100) |
| SF-1100-PTSi    |  | Inline (FM-1100i)      |
| SF-1100-PTSi-00 |  | No flow meter          |

| Part#    | Description            | Inlet/Outlet |
|----------|------------------------|--------------|
| FM-1100  | Pump-mounted meter kit | 1" MNPT      |
| FM-1100i | In-line meter kit      | 1" FNPT      |

## General Safety Information

### NOTE

Notes are used to notify of installation, operation, or maintenance information that is important but not safety related.

### CAUTION

Caution is used to indicate the presence of a hazard, which will or may cause minor injury or property damage if the notice is ignored.

### WARNING

Warning denotes that a potential hazard exists and indicates procedures that must be followed exactly to either eliminate or reduce the hazard, and to avoid serious personal injury, or prevent future safety problems with the product.

### DANGER

Danger is used to indicate the presence of a hazard that will result in severe personal injury, death, or property damage if the notice is ignored.

### CAUTION

"Intermittent Duty" is defined as: operated and/or frequently started within a period of time that would cause the motor to reach its maximum thermal limits. Once the maximum thermal limit is obtained, the motor must be allowed to return to ambient temperature before resuming operation.

### CAUTION

DO NOT use to pump flammable liquids. Never operate the pump in an explosive environment. Arcing from the motor brushes, switch or excessive heat from an improperly cycled motor may cause an explosion.

### CAUTION

DO NOT assume fluid compatibility. If the fluid is improperly matched to the pumps' elastomers, a leak may occur. Pumps used to transfer hazardous or hot (max. temperature 130°F [54.4°C]) chemicals must be in a vented area to guard against the possibility of injury due to harmful or explosive liquid/vapors.

### CAUTION

DO NOT operate the pump at pressures which cause the motor to exceed the amperes rating indicated on the name plate. DO NOT operate the pump at voltages which exceed the voltage rating indicated on the name plate. Operating the pump beyond the indicated ratings may cause the motor to overheat.

### CAUTION

To prevent electrical shock, disconnect power before initiating any work. In the case of pump failure, the motor housing and/or the pumped fluid may carry high voltage to components normally considered safe.

### CAUTION

Model SF-1100-110V must be connected to a circuit with Ground Fault Circuit Interrupt protection (GFCI) for safe operation. This may be achieved by use of a GFCI-protected 110V receptacle, or by use of a GFCI-equipped patch cord. Failure to comply with this instruction may result in damage to property and/or injury to persons. The SF-1100-110V includes a 2.5 amp, slow-blow internal fuse that will trip under overload conditions if not connected to a GFCI, rendering the unit permanently inoperable.

## Hazardous Substance Alert

1. Always drain and flush pump before servicing or disassembling for any reason (see instructions).
2. Always drain and flush pump prior to returning unit for repair.
3. Never store pumps containing hazardous chemicals.
4. Before returning pump for service/repair, drain out all liquids and flush unit with neutralizing liquid. Then, drain the pump. Attach tag or include written notice certifying that this has been done.

### NOTE

It is illegal to ship or transport any hazardous chemicals without United States Environmental Protection Agency Licensing.

# Model SF-1100 Mini-Bulk Chemical Transfer System

The SF-1100 Transfer Pump is a 12-Volt DC, self-priming, positive-displacement diaphragm pump. It is designed for non-flammable fluid transfer and recirculation. The pump includes a 20' power cord with alligator clips and an inline fuse. It features a 2-inch NPT inlet and a 1-inch NPT discharge port.

The SF-1100 pump is intended for intermittent duty. Be certain the pump materials will be compatible with the fluid being pumped. If unsure of the chemical compatibility with a given elastomer or the motor's intended design, please call SHURflo for assistance.

- Self-priming, positive displacement
- Chemical-resistant materials
- Ability to handle high to low viscosity liquids
- 5-chamber design increases durability

## Construction Materials

**Upper Housing:** Polypropylene

**Valve Housing:** Polypropylene

**Valves (SF-1100-00):** EPDM

**Pump Head Screws:** Stainless Steel\*

\*Not in fluid path

**O-ring:** Viton

**Diaphragm:** Santoprene

**Valves (SF-1100-05):** Viton

**Lower Housing:** Aluminum\*

## SF-1100 Usage Instructions

1. Be sure to use Teflon<sup>®</sup> tape for any and all connections made to the pump.
2. Connect appropriate size and length of tubing for current application.
3. Ensure all connections are tight.
4. Ensure the power switch on the pump is in the OFF position.

### 5A. (DC Versions Only)

Connect the alligator clips on ends of power wires to the appropriate connections to provide power to the system.

**NOTE:** The RED wire is the positive (+) 12-Volt connection. The BLACK wire is the negative (-) 12-Volt connection.

**12-VOLT BATTERIES CAN PRESENT A HAZARDOUS, EXPLOSIVE ENVIRONMENT. BEFORE MAKING ANY BATTERY CONNECTIONS, ASSURE PUMP SWITCH IS IN THE OFF POSITION. ASSURE PUMP'S BATTERY CONNECTIONS ARE TIGHT BEFORE OPERATING PUMP.**

### 5B. (AC Versions Only)

#### **CAUTION**

**Model SF-1100-110V must be connected to a circuit with Ground Fault Circuit Interrupt protection (GFCI) for safe operation. This may be achieved by use of a GFCI-protected 110V receptacle, or by use of a GFCI-equipped patch cord. Failure to comply with this instruction may result in damage to property and/or injury to persons. The SF-1100-110V includes a 2.5 amp, slow-blow internal fuse that will trip under overload conditions if not connected to a GFCI, rendering the unit permanently inoperable.**

6. Once the system is ready, turn the power switch to the ON position.
7. Operate pump until no longer needed.
8. When complete, be sure to turn the power switch to the OFF position.

## Flushing

If pump is to not be used for an extended period of time, it is suggested to flush any chemicals from the pump with fresh water. Flushing the pump will ensure a long, problem-free life and easy start-up when the pump is needed again.

**NOTE:** DO NOT flush with petroleum-based chemicals. Use only water to flush the SF-1100 Chemical Transfer pump. Be sure to properly dispose of the contaminated rinse water.

## SF-1100 Parts Kits List / Parts Drawing

| Ref. No. | Kit Part No. | Description                                |
|----------|--------------|--|
| 1        | 94-718-00    | Motor Assembly Kit                         |
| 2        | 94-719-00    | Diaphragm/Lower Housing/Drive Assembly Kit |
| 3a       | 94-720-00    | Valve Housing Assembly Kit (EPDM)          |
| 3b       | 94-720-05    | Valve Housing Assembly Kit (Viton)         |
| 4        | 94-721-00    | Upper Housing Assembly Kit                 |

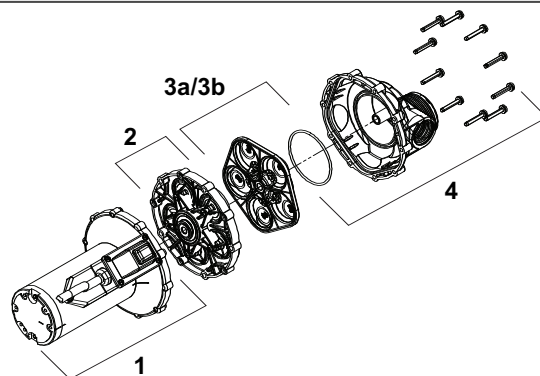

## Troubleshooting

| Symptom   | Corrective Action(s)   |
|---|--|
| Pump will not start:                              | <ul style="list-style-type: none"> <li>Check inline fuse.</li> <li>Check for correct voltage (<math>\pm 10\%</math>) and electrical connections.</li> <li>Check motor for open or grounded circuit.</li> <li>Check for locked drive assembly.</li> </ul>   |
| Pump will not prime:<br>(no discharge/motor runs) | <ul style="list-style-type: none"> <li>Check to see if out of product.</li> <li>Check inlet for debris.</li> <li>Check for inlet plumbing joints for good seal.</li> <li>Check for severe vacuum leak.</li> <li>Check dip tube for blockage or restriction.</li> <li>Check to see if inlet/outlet tubing is severely restricted (kinked).</li> <li>Check for debris in pump inlet/outlet valves.</li> <li>Check for proper voltage with the pump operating (<math>\pm 10\%</math>).</li> <li>Inspect pump housing for cracks.</li> <li>Inspect pump for loose screws.</li> </ul> |
| Pump leaks:                                       | <ul style="list-style-type: none"> <li>Check for loose screws.</li> <li>Check to see if diaphragm is ruptured, pinched or punctured.</li> </ul>  |
| Noisy / rough operation:                          | <ul style="list-style-type: none"> <li>Check for loose pump head or drive screws.</li> </ul>   |

## Models SF-1100-REC and SF-1100-REC-DT

### Assembly Instructions

1. Remove parts from shipping box.
2. Remove end cap from hose assembly and apply approximately 10 turns of Teflon tape on to the threads.
3. Install taped threads into 3-way ball valve.
4. Remove end cap from opposite end of hose assembly and repeat step three.
5. Install taped threads into flow meter/spigot assembly.
6. Install dip tube (DT model only) to pump inlet on underside of tank lid. Nipple on tank lid is sized for 1" tube. Tighten hose clamp supplied to secure tube to tank nipple. Non-DT

model needs to have dip tube supplied separately.

7. Install pump/lid assembly to mini-bulk tank. Secure pump motor to tank using bracket provided.

### Usage Instructions

1. Connect the alligator clips on the ends of the power wires to the appropriate connections to provide power to the system.  
**Note:** the RED wire is the positive (+) 12-Volt connection. The Black wire is the negative (-) 12-Volt connection.
2. Use ON/OFF switch on motor to power pump.
3. The 3-way ball valve can be used to route chemical either to discharge spigot or to recirculate back to the mini-bulk tank.

## Model SF-1100-PTS Portable Transfer System

### Assembly Instructions

1. Remove parts box from center of main shipping box.
2. Remove hose assemblies from main shipping box. (See Figure #1)
3. Remove Portable Transfer System from main shipping box.
4. Remove end cap from one hose assembly and apply approximately 10 turns of Teflon<sup>®</sup> tape (supplied) to the pipe threads of hose assembly.
5. Remove caplug from flow meter discharge elbow.
6. Thread end of hose assembly with Teflon tape into the discharge elbow of the flow meter.
7. Remove other end cap from hose assembly and apply approximately 10 turns of Teflon tape to the pipe threads of hose assembly.

8. Remove ball valve/nozzle assembly from parts box and thread onto the pipe threads of the hose assembly. (See Figure #1)
9. Remove end cap from remaining hose assembly and apply approximately 10 turns of Teflon tape to the pipe threads of hose assembly.
10. Thread end of hose assembly with Teflon tape into the 2" to 1" pump inlet reducer fitting.
11. Remove other end cap from hose assembly and apply approximately 10 turns of Teflon tape to the pipe threads of hose assembly.
12. Remove the female pump suction coupler assembly from parts box and thread onto the pipe threads of the hose assembly. (See Figure #1)

## Usage Instructions

1. Remove the plug from tank coupler on the Mini-Bulk storage tank. (Save plug for later use.)
2. Align the female pump suction coupler fitting with the tank coupler and lower onto the tank.
3. Lift levers on the female pump suction coupler fitting to lock onto tank coupler.
4. Connect the alligator clips on ends of power wires to the appropriate connections to provide power to the system. **NOTE:** The RED wire is the positive (+) 12-Volt connection. The BLACK wire is the negative (-) 12-Volt connection.

**CAUTION** 12-volt batteries can present a hazardous, explosive environment. Before making any battery connections, assure pump switch is in the off position. Assure pump's battery connections are tight before operating pump.

### NOTE

System has been approved for use with Monsanto's products. If using any other chemicals, ensure chemical compatibility between liquid to be pumped and the pump's wetted parts before using.

### NOTE

The SF-1100-PTS Portable Transfer System is specifically designed for non-flammable fluid transfer and recirculation. DO NOT use with fluids that have a flashpoint lower than 100°F.

## Dispensing Instructions

1. Open manual vent on top of tank.
2. Ensure valve on pump suction coupler is in the open position.
3. Reset flow meter to zero.
4. Turn power switch on SF-1100 dispensing pump to the ON position.

### NOTE

Be sure to have valve spout over container before opening ball valve.

5. Turn handle on ball valve assembly to dispense chemical.
6. When desired amount of chemical has been dispensed, close handle on ball valve assembly.
7. Turn **off** power to pump.
8. Ensure valve on pump suction coupler assembly is **closed** prior to removing coupler from tank to prevent spillage.

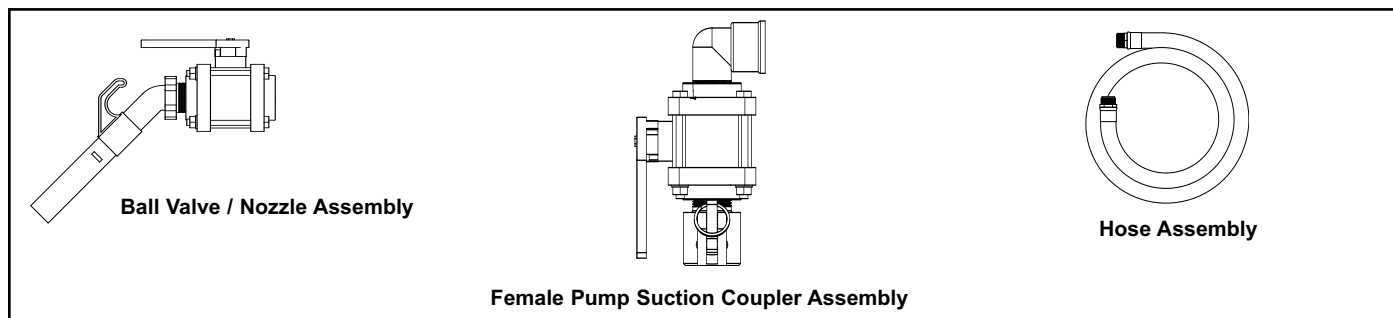

Figure 1: SF-1100-PTS Components

## Model FM-1100 / FM-1100i Electronic Flow Meter

The SHURflo FM-1100 Series Electronic Flow Meters are highly accurate, positive displacement, nutating disk, fluid-metering devices. The FM-1100 meter is designed for mounting to a pump or other device that can provide support to the meter. The FM-1100i meter may be mounted at the dispense end of the hose. The inlet connection on the meter should be connected to the hose and a shut-off valve should be connected to the outlet connection.



- Simple, one-touch operation
- Large, 0.8" LCD display characters
- Choice of three calibration modes
- Large, easy-to-press buttons (even when wearing gloves)

### Construction Materials

**90° Meter Housing:** .....Nylon 6  
**Inline Meter Housing:** ....Nylon 6/5  
**Seal Cover:** .....Polypropylene  
**Nutating Chamber:** Polyphenylene Sulfide (PPS)  
**O-ring (inside):** .....Viton  
**O-ring (outside):**.....Buna-N  
**Meter Bayonet Cap / Cap Lock**.... Polypropylene  
**Screws:** .....Stainless Steel

# Model FM-1100 / FM-1100i Electronic Flow Meter - cont'd.

## Operation

As fluid flows through the meter, it causes the nutating disk to wobble, which causes the rotation of a magnet wheel. The meter's electronic assembly counts the number of revolutions of this magnet, which determines, based on the calibration setting, the quantity of liquid that has passed through the meter. The self-contained electronic assembly features a large Liquid Crystal Display (LCD) and simple three-button operation.

### NOTE

Ensure chemical compatibility between liquid to be metered and the meter's wetted parts before using.

### NOTE

Meter should NOT be used for flammable petroleum products. DO NOT use with fluids that have a flashpoint lower than 100° F.

## Specifications for Nutating Disk

- Powered by a replaceable 3-Volt lithium battery. (Estimated normal use life = 4+ years).
- The LCD display has four 0.8" numerical digits with decimal points.
- The LCD display has a:
  - LOW BATTERY (LOW) indicator,
  - CURRENT TOTAL (CUR) indicator,
  - CUMULATIVE TOTAL (CUM) indicator,
  - GALLONS (GAL) indicator,
  - LITERS (LTR) indicator,
  - COUNTS (CNT) indicator, and a
  - CALIBRATE (CAL) indicator.

## Meter Installation Procedures

### FM-1100

Thread the meter inlet into the discharge port of the pump. Using an elbow or coupling, screw the discharge hose onto the outlet port of the meter. Use thread sealant tape or pipe dope to seal threaded connections.

### FM-1100i

Meter is designed to be used inline, near the point of delivery. Using an elbow or coupling, hoses can be attached directly to the inlet and discharge ports. Use thread sealant tape or pipe dope to seal threaded connections.

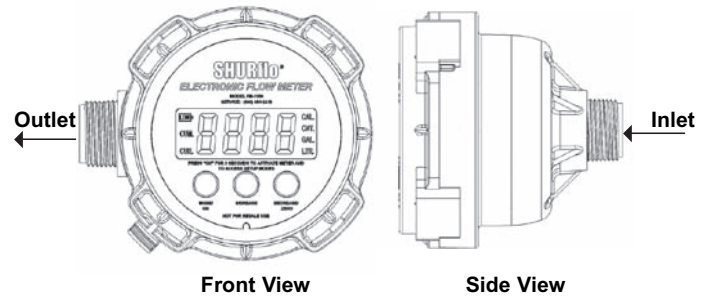

Figure 2: FM-1100

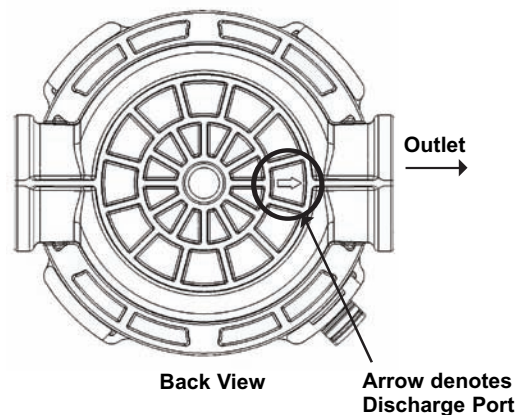
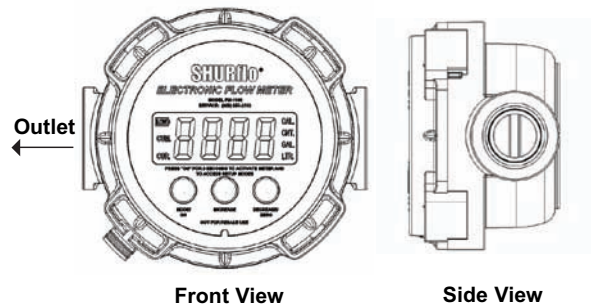

Figure 3: FM-1100i



## Meter Operation



The FM-1100 Series Flow Meter has three push buttons:  
**1** MODE or "ON" button      **2** INCREASE (up arrow) button      **3** DECREASE (down arrow) or "ZERO" button



MODE/  
ON



INCREASE

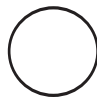

DECREASE/  
ZERO

### The meter displays and stores:

- A resettable CURRENT TOTAL (CUR)
- A non-resettable CUMULATIVE TOTAL (CUM)
- A COUNTS calibration value (CNT)

### The MODE button performs the following functions:

1. If the display is off, press MODE button to display current total (CUR).
2. Use MODE button to cycle between CURRENT TOTAL (CUR) and CUMULATIVE TOTAL (CUM).

**NOTE:** After approximately 30 seconds, display will automatically switch from CUMULATIVE TOTAL (CUM) back to CURRENT TOTAL (CUR).

3. Press and hold MODE button for 3–5 seconds to show Volume Unit Selection. Press INCREASE or DECREASE buttons to cycle through volume units. When desired units are flashing, press MODE button to save selection and return to CURRENT TOTAL (CUR).

Volume Unit Selection choices are: GALLONS (GAL), LITERS (LTR), or COUNTS (CNT).

**NOTE:** To reset CURRENT TOTAL (CUR) to Zero, press and hold DECREASE button for 2 seconds or more while CURRENT TOTAL (CUR) is displayed.

**NOTE:** Meter will not enter Volume Unit Selection mode if pump is running.

**CUMULATIVE TOTAL CANNOT BE RESET - EVEN BY REMOVING THE BATTERY.**

- The flow meter display will turn on whenever flow is detected.
- The flow meter will turn off and blank the display after a 3-minute period of button or flow inactivity. Any unsaved changes will not be saved.

## Calibration Procedures

- Calibration procedures are the same for both the 90° and inline meters.
- To ensure accuracy, purge all air from pump/meter system before calibrating.

### To CALIBRATE (CAL) meter:

1. Press MODE button to turn meter on.
2. Press and hold MODE button for 3–5 seconds to show Volume Unit Selection. Press INCREASE or DECREASE buttons to select desired Volume Units.
3. Press and hold MODE button again for 3–5 seconds to enter Calibration Mode (CAL).
4. CAL and chosen Volume Unit (GAL or LTR) will blink together. Numeric Display will show default values as listed below.

| Flashing Indicators  | Numeric Display |
|--|-----------------|
| Calibrate Liters (LTR)   | 20.00           |
| Calibrate Gallons (GAL)  | 5.00            |
| Calibrate Counts (CNT)   | XXXX            |
| <b>NOTE:</b> XXXX represents the present COUNTS (CNT) value stored in flow meter's memory. To CALIBRATE using COUNTS (CNT), please see next section. |                 |

**NOTE:** To use a calibrated container with a volume other than the default values, press INCREASE or DECREASE buttons to change value shown on Numeric Display.

5. To complete CALIBRATION for GALLONS (GAL) or LITERS (LTR), pump the exact amount shown on Numeric Display.
6. Press MODE button for 3–5 seconds to SAVE the CALIBRATION. Display will show CAL if CALIBRATION was successful.

**NOTE:** If MODE button is pressed for less than 3 seconds, CALIBRATION will be aborted and display will show Err (Error) to indicate the CALIBRATION was not successful. Display will return to CURRENT TOTAL (CUR) without making any changes.

### To CALIBRATE (CAL) meter using COUNTS (CNT) value:

**NOTE:** No pumping is required to complete CALIBRATION (CAL) for COUNTS (CNT).

1. Press MODE button to turn meter on.
2. Press and hold MODE button for 3–5 seconds to show Volume Unit Selection. Press INCREASE or DECREASE buttons to select COUNTS (CNT).
3. Press and hold MODE button again for 3–5 seconds to enter Calibration Mode (CAL).

4. CALIBRATE (CAL) and COUNTS (CNT) indicators will both blink together. Numeric Display will also show a value (XXXX), which represents the present value stored in flow meter's memory.
5. Press INCREASE or DECREASE buttons to change the value shown in Numeric Display to desired value.
6. To complete CALIBRATION for COUNTS (CNT), press MODE button for 3–5 seconds. CALIBRATE (CAL) and COUNTS (CNT) indicators will turn off and display will show CAL if CALIBRATION was successful.

**NOTE:** If MODE button is pressed for less than 3 seconds, CALIBRATION will be aborted and display will show Err (Error) to indicate the CALIBRATION was not successful. Display will return to CURRENT TOTAL (CUR) without making any changes.

### To Display Software Revision Number

1. Press MODE button to turn meter on.
2. Press MODE button again to display CUMULATIVE TOTAL (CUM).
3. While display is showing CUMULATIVE TOTAL (CUM), press and hold DECREASE button to display flow meter's software revision number (e.g. r1.00).

**CUMULATIVE TOTAL CANNOT BE RESET - EVEN BY REMOVING THE BATTERIES.**

## FM-1100 & FM-1100i Kits List / Parts Drawing

| ITEM | KIT PART NO. | DESCRIPTION                   |
|------|--------------|-------------------------------|
| (1)  | 94-732-00    | Electronic Assembly Kit       |
| (2)  | 94-733-00    | Meter Housing Seal Cover Kit  |
| (3)  | 94-734-00    | Nutating Chamber Assembly Kit |
| (4a) | 94-735-00    | 90-Degree Meter Housing Kit   |
| (4b) | 94-736-00    | Inline Meter Housing Kit      |

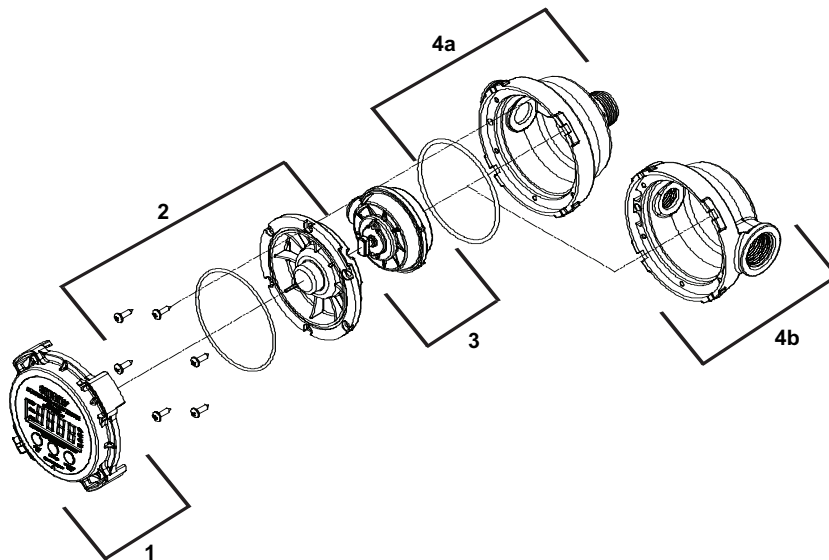

To purchase parts, please contact our Sales Department at 800-424-9776.

# Troubleshooting

| <b>Symptom</b>                      | <b>Corrective Action(s)</b>   |
|-------------------------------------|---|
| Meter display will not turn on:     | <ul style="list-style-type: none"><li>Check for dead battery.</li><li>Check electronics chamber for moisture.</li><li>Check o-ring seal for damage.</li><li>Check to see that PCB assembly is properly seated.</li><li>Check to see that battery is properly seated / no corrosion.</li><li>Check for damaged magnetic switch/PCB.</li></ul>                                |
| Meter shows no flow:<br>(pump runs) | <ul style="list-style-type: none"><li>Check low battery indicator.</li><li>Check for damaged magnetic switch/PCB.</li><li>Check magnetic wheel assembly.</li><li>Check nutating chamber for debris.</li><li>Check to see if outlet tube is severely restricted (kinked).</li><li>Check for missing magnet wheel assembly.</li><li>Check to see if out of product.</li></ul> |
| Flow low/high/inconsistent:         | <ul style="list-style-type: none"><li>Check for air in system.</li><li>Check for calibration error (Err).</li><li>Check for particulates in fluid.</li><li>Check for damaged nutating chamber.</li></ul>  |
| Meter leaks:                        | <ul style="list-style-type: none"><li>Check for damaged o-ring.</li><li>Check for loose screws.</li><li>Check inlet/outlet fittings for proper seal.</li><li>Check meter housing for cracks.</li></ul>  |
| Noisy / rough operation:            | <ul style="list-style-type: none"><li>Check nutating chamber for debris.</li><li>Check for loose magnetic wheel assembly.</li></ul>   |

# Mini-Bulk Pump & Flow Meter Kits

## Motor Assembly Kit (Part# 94-718-00)



The 94-718-00 is the motor assembly used in any SF-1100 Series Pump.

**The motor assembly kit includes:**

- 12 VDC motor with 20 ft. cable, alligator clips & inline fuse
- Integrated pump lower housing
- Built-in on-off switch

## Valve Housing Kits



The replacement valve housings include a complete, fully-assembled valve housing with o-ring seal ready for installation. Available with EPDM or Viton® valves.

**Manufacturer recommends replacing the o-ring seal whenever the pump has been taken apart.**

### Order Information

| Part#     | Description   |
|-----------|---------------|
| 94-720-00 | EPDM valves   |
| 94-720-05 | Viton® valves |

## FM-1100 Series Meter Electronics Kit (Part# 94-732-00)



The 94-732-00 Flow Meter Electronics Kit includes the front cover assembly and the electronic display including o-ring and batteries. The electronics kit will fit both the pump-mounted and inline meters.

## FM-1100 Series Meter Nutating Chamber Assembly Kit (Part# 94-734-00)



The 94-734-00 is a replacement chamber assembly which includes the o-ring seal. The nutating chamber assembly kit will fit both the pump-mounted and inline meters.

## Diaphragm/Lower Housing/Drive Assembly Kit (Part# 94-719-00)



The 94-719-00 is a replacement Santoprene® diaphragm/lower housing/drive assembly ready for installation.

## Pump Housing Kit (Part# 94-721-00)



The 94-721-00 is a replacement polypropylene upper housing which includes the o-ring seal and pump head screws.

**Manufacturer recommends replacing the o-ring seal whenever the pump has been taken apart.**

## FM-1100 Series Meter Housing Seal Cover Kit (Part# 94-733-00)



The 94-733-00 Flow Meter Housing Seal Cover Kit includes the seal cover, o-ring and screws. The flow meter housing seal cover will fit both the pump-mounted and inline meters.

## FM-1100 Series Meter Housing Kits



Replacement meter housings for pump-mounted or inline flow meters.

| Part#     | Description                                       |
|-----------|---|
| 94-735-00 | Replacement 90° meter housing with O-ring seal    |
| 94-736-00 | Replacement inline meter housing with O-ring seal |

## Mini-Bulk Parts & Accessories

### 90° Elbow Fitting Kit (Part# 94-712-00)



The 94-712-00 is a replacement 2-in. street elbow. Fitting has 2-in. male NPT threads on one side and 2-in. female NPT threads on the other.

### Discharge Hose Kit (Part# 94-717-00)



The 94-717-00 is a replacement 1-in. NPT x 12 ft. EPDM hose.

### Recirculation Lid Kit (Part# 94-724-00)



The 94-724-00 is a replacement lid for the Mini-Bulk Chemical Recirculation system.

### Recirculation System Return Hose Kit (Part# 94-737-00)



The Recirculation System Return Hose Kit includes the return hose and two hose clamps.

### Ball Valve/Spout Kit (Part# 94-716-00)



The 94-716-00 is a replacement 1-in. NPT ball valve with spout.

### Alligator Clips/Fuse Kit (Part# 94-723-00)



The 94-723-00 is a replacement set of red and black alligator clips, including a fuse holder.

### Recirculation Cap Kit (Part# 94-725-00)



The 94-725-00 is a replacement cap for the Mini-Bulk Chemical Recirculation system.

### Elbow/Valve/Coupling Kit (Part# 94-738-00)



The 94-738-00 is a replacement elbow/valve/coupling assembly, which includes a 1-in. street elbow, 1-in. ball valve and a 1-in. bayonet tank coupling.

## Limited Warranty on Hypro/SHURflo Agricultural Pumps & Accessories

Hypro/SHURflo (hereafter, "Hypro") Bulk Chemical Pumps are warranted to be free of defects in material and workmanship under normal use, for a period of five (5) years from the date of purchase, with proof of purchase. This limited warranty will not exceed five (5) years, in any event. Hypro flow meters are warranted for a period of one (1) year from date of purchase, with proof of purchase. All other components and accessories are warranted for a period of ninety (90) days, with proof of purchase.

This limited warranty will not apply to products that were improperly installed, misapplied, damaged, altered, or incompatible with fluids or components not manufactured by Hypro. All warranty considerations are governed by Hypro's written return policy.

Hypro's obligation under this limited warranty policy is limited to the repair or replacement of the product. All returns will be tested per Hypro's factory criteria. Products found not defective (under the terms of this limited warranty) are subject to charges paid by the returnee for the testing and packaging of "tested good" non-warranty returns.

No credit or labor allowances will be given for products returned as defective. Warranty replacement will be shipped on a freight allowed basis. Hypro reserves the right to choose the method of transportation.

This limited warranty is in lieu of all other warranties, expressed or implied, and no other person is authorized to give any other warranty or assume obligation or liability on Hypro's behalf. Hypro shall not be liable for any labor, damage or other expense, nor shall Hypro be liable for any indirect, incidental or consequential damages of any kind incurred by the reason of the use or sale of any defective product. This limited warranty covers agricultural products distributed within the United States of America. Other world market areas should consult with the actual distributor for any deviation from this document.

### Return Procedures

All products must be flushed of any chemical (ref. OSHA section 1910.1200 (d) (e) (f) (g) (h)) and hazardous chemicals must be labeled/tagged before being shipped\* to Hypro for service or warranty consideration. Hypro reserves the right to request a Material Safety Data Sheet from the returnee for any pump/product it deems necessary. Hypro reserves the right to "disposition as scrap" products returned which contain unknown fluids. Hypro reserves the right to charge the returnee for any and all costs incurred for chemical testing, and proper disposal of components containing unknown fluids. Hypro requests this in order to protect the environment and personnel from the hazards of handling unknown fluids.

Be prepared to give Hypro full details of the problem, including the model number, date of purchase, and from whom you purchased your product. Hypro may request additional information, and may require a sketch to illustrate the problem.

**Contact Hypro Service Department at 800-468-3428 to receive a Return Merchandise Authorization number (RMA#).** Returns are to be shipped with the RMA number clearly marked on the outside of the package. Hypro shall not be liable for freight damage incurred during shipping. Please package all returns carefully. All products returned for warranty work should be sent **shipping charges prepaid** to:

HYPRO  
Attention: Service Department  
375 Fifth Avenue NW  
New Brighton, MN 55112

For technical or application assistance, call the **Hypro Technical/Application number: 800-445-8360**, or send an email to: **technical@hypropumps.com**. To obtain service or warranty assistance, call the **Hypro Service and Warranty number: 800-468-3428**; or send a fax to the **Hypro Service and Warranty FAX: 651-766-6618**.

\*Carriers, including U.S.P.S., airlines, UPS, ground freight, etc., require specific identification of any hazardous material being shipped. Failure to do so may result in a substantial fine and/or prison term. Check with your shipping company for specific instructions.



**Pentair**

**SPRAY & INJECTION TECHNOLOGIES GROUP**

375 Fifth Avenue NW • New Brighton, MN 55112

Phone: (651) 766-6300 • 800-424-9776 • Fax: 800-323-6496

[www.hypropumps.com](http://www.hypropumps.com)