

OWNER'S MANUAL

Model: LS10-110 (5301080)

(110 Gallon, 5.5 HP Skid Sprayer)

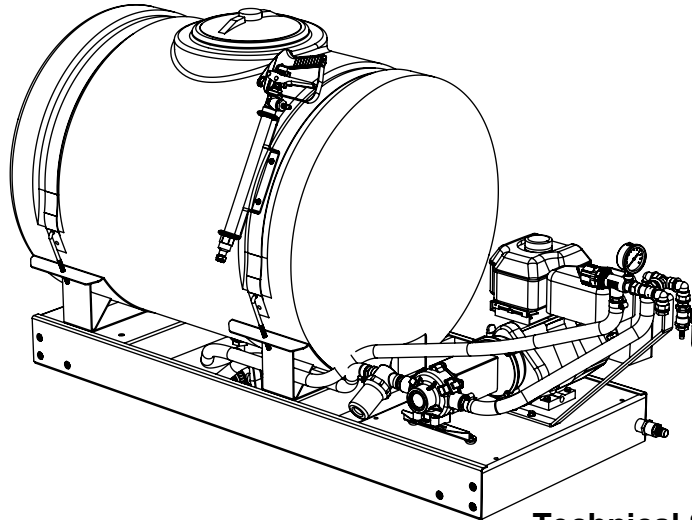

Technical Specifications

- 110 Gallon Polyethylene Tank
- 5.5 HP Recoil Start Engine w/Gear Reduction
- 8-Roller Cast Iron Pump
- 10 g.p.m. @ 250 PSI
- Pressure Gauge - Adjustable Pressure Range
- Suction Line Filter
- Handgun w/25 Feet of Hose
- Tank Drain Feature
- (Optional) Trailer Kit Available

Operation

Roller pumps are positive displacement pumps which means that the entire solution being pumped must go somewhere or the pump will break. In this roller pumping system, solution is drawn from the tank and forced to a planned source such as a handgun. The pressure is controlled by a relief valve which is a spring loaded device that controls the amount of fluid bypassed to the tank. The handle is to be tightened to increase pressure and loosened to decrease the pressure. The suction line strainer should be checked periodically and cleaned. Stop the engine and shut off the valve near the strainer. Remove the bowl and screen portions of the strainer and wash them free from all impurities. You may also drain the tank by uncoupling the suction line near the strainer. Open the valve and pour the contents into another container. Read the chemical label for disposal instructions.

NOTICE: The engine does not have any oil in the crankcase. See the engine manual for type and amount. Always check the oil in the gear box. Remove the plug on the side, oil should be visible. Add oil through the top plug.

BEFORE RETURNING THIS PRODUCT FOR ANY REASON, PLEASE CALL

1-800-274-1025

IF YOU SHOULD HAVE A QUESTION OR EXPERIENCE A PROBLEM WITH YOUR SCHABEN INDUSTRIES PRODUCT:

1-800-274-1025

BEFORE YOU CALL, PLEASE HAVE THE FOLLOWING INFORMATION AVAILABLE: SALES RECEIPT & MODEL NUMBER. IN MOST CASES, A SCHABEN INDUSTRIES EMPLOYEE CAN RESOLVE THE PROBLEM OVER THE PHONE.

General Information

Thank you for purchasing this product. The purpose of this manual is to assist you in operating and maintaining your skid sprayer. Please read it carefully, as it furnishes information which will help you achieve years of trouble-free operation.

Warranty/Parts/Service

Products are warranted for one year from date of purchase against manufacturer or workmanship defects.

Commercial users have a 90 day warranty.

Your authorized dealer is the best source of replacement parts and service. To obtain prompt, efficient service, always remember to give the following information...

- Correct Part Description and/or part number.
- Model number/Serial number of your sprayer.

Part descriptions and part numbers can be obtained from the illustrated parts list section(s) of this manual.

Whenever you need parts or repair service, contact your distributor/dealer first. For warranty work, always take your original sales slip, or other evidence of purchase date, to your distributor/dealer.

SCHABEN

I N D U S T R I E S

www.schabenindustries.com

5834 E. 23rd St. 239 S. Meridian 4450 State Rd.
Columbus, NE 68601 Newton, KS 67114 Bakersfield, CA 93308
402-564-4544 316-283-4444 661-391-9081

Form No. 1076 [5004684 (04/14)] Printed in the U.S.A.

Testing the Sprayer

NOTE:

It is **VERY** important for you to test your sprayer with plain water before actual spraying is attempted. This will enable you to check the sprayer for leaks, without the possibility of losing any expensive chemicals.

Read the operating instructions.

1. Open tank lid and be sure the tank is clean and free of foreign material. Fill the tank about half full with plain water.
2. Open the valve at the strainer inlet and allow water to flow to the pump. The valve is located at this point to enable the strainer to be taken apart for cleaning.

CAUTION: Always be sure that water has reached the roller pump before starting your sprayer. If the pump is run dry, serious damage to your pump will result.

3. It is best to start the sprayer at little or no pressure. This sprayer is equipped with a spring loaded relief valve. Turn the valve handle out to decrease pressure, and in for increased pressure.

4. You may now start the sprayer engine following the engine manufacturer's instructions. Let the sprayer run at low pressure until water has reached the handgun, and all air has been purged from the handgun line.

CAUTION: Care must be taken, being sure the handgun is secured in the operator's hand. If this is NOT done, a recoiling action may occur causing damage or personal injury.

5. The pressure should now be increased to 30-40 psi. Operate the sprayer at this increased pressure for 3 to 5 minutes, thoroughly testing the unit before adding chemicals.

When everything tests all right (no leaks, & good pressure), add the desired chemicals to the mixture and water combination and start your spraying operation. Adjust the pressure and spray as you did in the testing procedure. The sprayer should now be ready for use.

Conditions of weather and terrain must be considered when setting the sprayer. Do not spray on windy days. Protective clothing must be worn in some cases.

Be sure to read the chemical label(s) correctly!

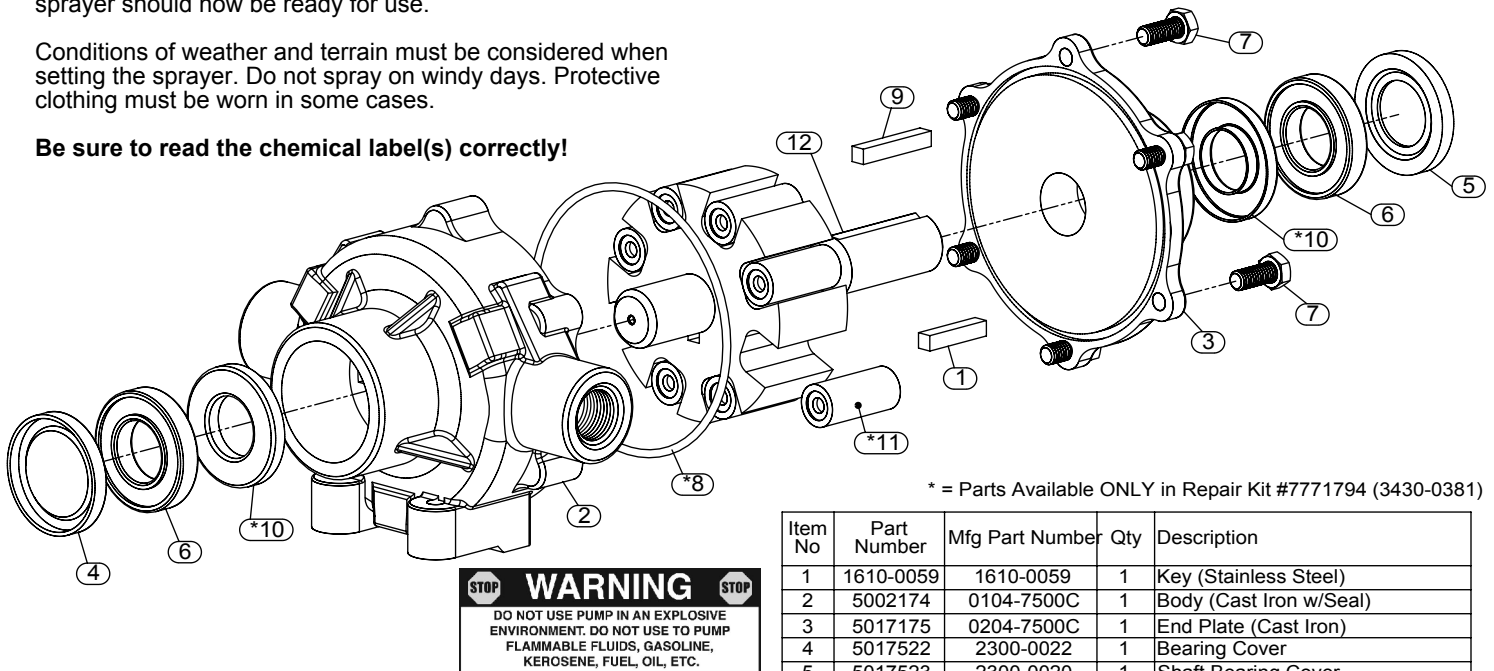

* = Parts Available ONLY in Repair Kit #7771794 (3430-0381)

Performance Data For Pump No: 5271509 (7560C-R-01)

Pump Speed (RPM)	0 PSI		50 PSI		100 PSI		150 PSI		200 PSI		250 PSI		300 PSI	
	GPM	HP	GPM	HP	GPM	HP	GPM	HP	GPM	HP	GPM	HP	GPM	HP
600	14.0	.45	13.1	.87	12.1	1.41	11.2	1.98	10.6	2.5	10.0	3.1	9.1	3.7

After Spraying

After use, fill the sprayer tank part way with water. Start the sprayer, and allow the clear water to be pumped through the plumbing system and out through the spray nozzles.

Refill the tank about half full with plain water and use FIMCO Tank Neutralizer and Cleaner, and repeat cleaning instructions above. Flush the entire sprayer with the neutralizing/cleaning agent, then flush out one more time with plain water. Follow the chemical manufacturer's disposal instructions of all wash or rinsing water. For the boom, (if applicable) remove the tips and screens from the nozzle assemblies. Wash these items out thoroughly. Blow the orifice clean and dry. If the orifice remains clogged, clean it with a fine bristle (NOT WIRE) brush, or with a toothpick. Do not damage the orifice. Water rinse and dry the tips before storing.

WARNING: Some chemicals will damage the pump valves if allowed to soak untreated for a length of time! ALWAYS flush the pump as instructed after each use.

Winter Storage

Drain all water out of your sprayer, paying special attention to the pump, handgun, and valve(s). These items are especially prone to damage from chemicals and freezing weather.

The sprayer should be winterized before storage by pumping a solution of RV antifreeze through the entire plumbing system. This antifreeze solution should remain in the plumbing system during the winter months. When spring time comes and you are preparing your sprayer for the spray season, rinse the entire plumbing system out, clearing the lines of the antifreeze solution. Proper care and maintenance will prolong the life of your sprayer.

Cast Iron 8-Roller,
Reverse Rotation Pump Assembly
#5271509 (Hypro Part #7560C-R-01)

Item No	Part Number	Mfg Part Number	Qty	Description
1	1610-0059	1610-0059	1	Key (Stainless Steel)
2	5002174	0104-7500C	1	Body (Cast Iron w/Seal)
3	5017175	0204-7500C	1	End Plate (Cast Iron)
4	5017522	2300-0022	1	Bearing Cover
5	5017523	2300-0020	1	Shaft Bearing Cover
6	5031044	2008-0001	2	Sealed Ball Bearing
7	5034038	2210-0004	6	H.H.C.S. 5/16"-18nc x 3/4" Long
*8	5072059	1720-0014	1	O-Ring Gasket
9	5089012	1610-0005	1	Key
*10	5110058	2112-0003	2	Viton Seal (Standard)
*11	5112030	1005-0004	8	Super Roller (Standard)
12	5172113	0308-7560C	1	Rotor Assembly (7500C)

Item No.	Part Number	Qty	Description
1	**	1	Gasket, Nylon
2	**	1	Seat Plug, Seat Plate, Washer, & Core Sub-Assembly
3	**	1	Packing Washer, Type 302 Stainless Steel
4	**	3	Packing, Leather
5	5002203	1	Inlet Body, Aluminum
6	5002205	1	Handle Body, Aluminum
7	5006072	1	Stop Adjustment Nut, Steel - Zinc Plated
8	5006118	1	Locknut, Steel - Zinc-Plated
9	5006244	1	Stem Nut, Steel - Nickel Plated
10	5009080	1	Tubing, Aluminum
11	5016061	1	Washer, Stainless Steel
12	5016071	1	Spring Guide Washer, Type 302 Stainless Steel
13	5019069	1	Spring for Stop Adjustment Nut, Stainless Steel
14	5019083	1	Trigger Stop Spring, Stainless Steel
15	5019107	1	Main Spring, Stainless Steel
16	5046033	1	Cap, Aluminum
17	5063071	1	Orifice Disc, Stainless Steel
18	5072171	2	Gasket, Nylon
19	5076011	1	Trigger Guard, Steel - Nickel Plated
20	5077015	1	Guide Vane, Nylon
21	5084016	1	Nozzle Housing, Aluminum
22	5111017	2	Rivet, Steel - Zinc Plated
23	5117070	1	Spring Screw, Steel - Zinc Plated
24	5117143	1	Screw, Stainless Steel
25	5117165	1	Packing Screw, Aluminum
26	5131012	1	Trigger Stop, Steel - Nickel Plated
27	5132039	1	Stem, Type 416 Stainless Steel
28	5134010	1	Spring Stud, Stainless Steel
29	5166017	1	Trigger Guide, Steel - Nickel Plated
30	5166026	1	Trigger, Steel - Nickel Plated

Exploded View/Parts List:
GunJet Spray Gun #5163005
 (Spraying Systems Part No: AA43H-AL6)

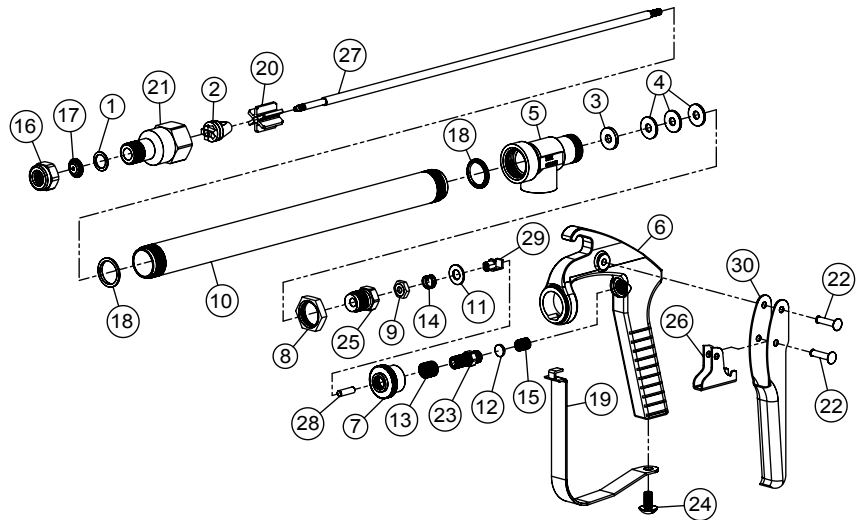

** = Available in Spare Parts Kit (ONLY):
 #5168190 (PK-AB43-AL-KIT)

PISTON TYPE PRESSURE RELIEF/REGULATING VALVES

Bypasses excess liquid. Adjustable to maintain control of line pressure at any pressure within the valve operating range. Selected pressure setting firmly held in place by locknut. Extra large passages to handle large flows.

- Polypropylene with stainless steel spring
- Excellent chemical resistance
- EPDM O-Rings
- For pressure to 150 p.s.i.
- 1/4" port for pressure gauge
- Choice of 1/2" or 3/4" NPT (M) inlet & (F) outlet connections

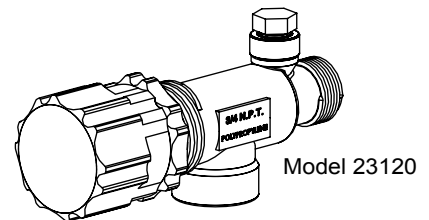
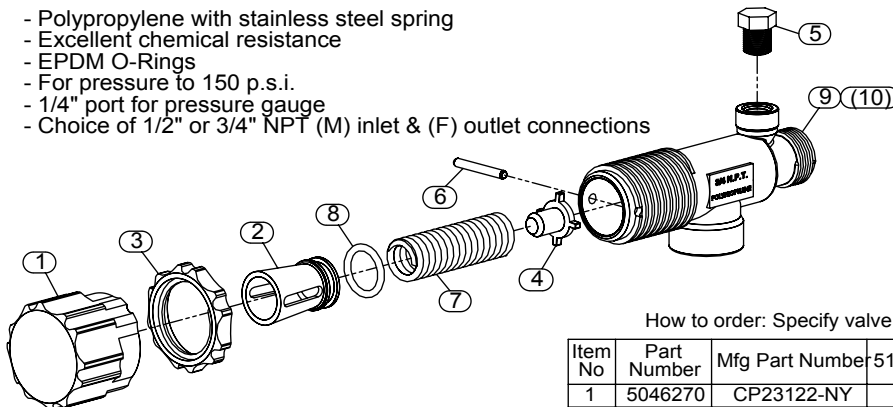

How to order: Specify valve number (Example: 23120-1/2-PP Polypropylene)

FIMCO Number	Mfg Part Number	Description
5143199	23120-3/4-PP	3/4" Poly Valve
5143200	23120-1/2-PP	1/2" Poly Valve
5168717	PK-AB23120-KIT	Repair Kit, Items Marked **

Item No	Part Number	Mfg Part Number	5143199/Qty	5143200/Qty	Description
1	5046270	CP23122-NY	1	1	Adjusting Cap, Nylon (Gray)
2	5108095	CP23124-PP	1	1	Spring Retainer
3	5110266	CP23123-PP	1	1	Lock Ring
4	5115078	CP23125-PP	1	1	Guide Seat
5	**	F14	1	1	Pipe Plug, 1/4" MNPT
6	**	CP23126-302SS	1	1	Retaining Pin
7	**	CP23127-302SS	1	1	Spring
8	**	CP7717-15-EPR	1	1	O-Ring, EPDM Rubber
9	---	CP23121-PP	1	-	Poly Body (3/4" NPT)
10	---	CP23128-PP	-	1	Poly Body (1/2" NPT)

Exploded View:
LS10-110 (5301080)

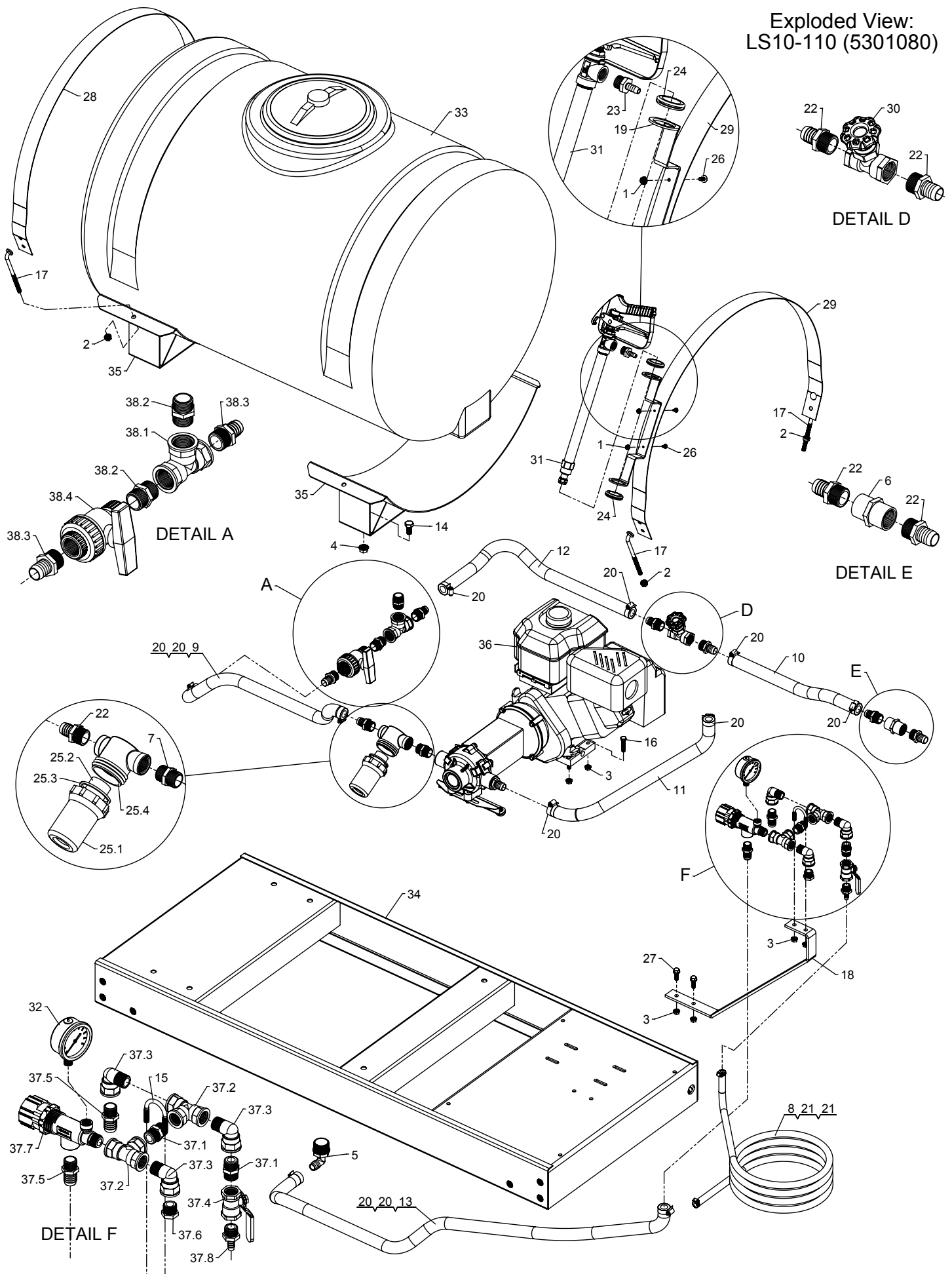

Parts List: LS10-110 (5301080)

Item No	Part Number	Qty	Description
1	5006186	2	#10-24 Hex Whiz (Flange) Locknut
2	5006259	4	3/8-16nc Hex Flanged Whiz Nut Gr. 5
3	5006307	8	5/16-18nc Hex Flanged Whiz Nut Gr. 5
4	5006337	4	1/2-13nc Hex Flanged Whiz Nut Gr. 5
5	5010214	1	Poly Elbow, 1 1/4" MNPT x 3/4" HB (3EL11434)
6	5010251	1	Poly Coupler, 3/4" FNPT
7	5011140	1	Poly Close Nipple, 3/4" MNPT
8	5020099	1	Hose, 3/8"-2 Brd. x 25 Ft.
9	5020469	1	Hose, 3/4"-2 Brd. x 32"
10	5020472	1	Hose, 3/4"-2 Brd. x 17"
11	5020473	1	Hose, 3/4"-2 Brd. x 27"
12	5020473	1	Hose, 3/4"-2 Brd. x 27"
13	5020485	1	Hose, 3/4"-2 Brd. x 64"
14	5034018	4	H.H.C.S., 1/2"-13 x 1"
15	5034063	1	Round U-Bolt, 5/16"-18 x 1 3/16" x 1 3/4"
16	5034069	4	H.H.C.S., 5/16"-18 x 1 1/2" (Full Thread)
17	5034734	4	3/8" x 6" Hook Bolt
18	5038586	1	Valve Mount Bracket
19	5038638	1	Handgun & Hose Bracket
20	5051024	10	Hose Clamp, 3/4"
21	5051144	2	Hose Clamp, 3/8"
22	5067127	5	Poly Fitting, 3/4" MNPT x 3/4" HB
23	5067130	1	Poly Fitting, 1/2" MNPT x 3/8" HB
24	5075014	2	Rubber Grommet (Black)
25	5116213	1	Strainer
25.1	3351-0039	1	Strainer Bowl
25.2	5116131	1	Screen (40 Mesh)

Item No	Part Number	Qty	Description
25.3	5072299	1	EPDM Gasket
25.4	3351-0038	1	Strainer Cap
26	5117234	2	#10-24 x 1/2" Phillips Truss Head Machine Screw
27	5117300	2	H.H.C.S. Flanged 5/16"-18nc x 1" Long
28	5133224	1	Tank Strap (110 Gallon)
29	5133229	1	Tank Strap (110 Gallon) (Hose Hanger Strap)
30	5143123	1	Valve Celcon Globe, 3/4"
31	5163005	1	GunJet Spray Gun (AA43H-AL6)
32	5167034	1	Gauge, Liquid-Filled, 0-400# p.s.i.
33	5169157	1	110 Gallon Tank (30" Dia. x 44" x 38") (Yellow)
34	5274365	1	Skid Weldment (110 Gallon)
35	5274366	2	Saddle Weldment (110 Gallon)
36	5275145	1	Engine/Pump Sub-Assembly
37	5277602	1	Top Valve Assembly (LS10)
37.1	5011139	2	Poly Close Nipple, 1/2" MNPT
37.2	5010230	2	Poly Tee, 1/2" FNPT
37.3	5010243	3	Poly Street Elbow, (90 Deg) 1/2" MNPT x 1/2" FNPT
37.4	5143197	1	1/2" T-800 Brass Ball Valve
37.5	5067133	2	Poly Fitting, 1/2" MNPT x 3/4" HB
37.6	5102070	1	Poly Pipe Plug, 1/2" MNPT
37.7	5143200	1	Pressure Relief Valve (1/2" NPT)
37.8	5067130	1	Poly Fitting, 1/2" MNPT x 3/8" HB
38	5277603	1	Tank Valve Assembly (LS10)
38.1	5010231	1	Poly Tee, 3/4" FNPT
38.2	5011140	2	Poly Close Nipple, 3/4" MNPT
38.3	5067127	2	Poly Fitting, 3/4" MNPT x 3/4" HB
38.4	5143206	1	3/4" Single Union Ball Valve

Engine/Pump Assembly #5275145

Item No	Part Number	Qty	Description
1	5005177	1	Adapter & Kit (Coupler)
2	5006186	2	#10-24 Hex Whiz (Flange) Locknut
3	5016026	2	Lockwasher, 5/16"
4	5023052	1	Torque Bracket
5	5034634	2	5/16"-18 x 5/8" Grd. 5 Flange Lock Screw (Serr.)
6	5040004	2	Rubber-Headed Machine Screw Bumper (#10-24)
7	5067127	1	Poly Fitting, 3/4" MNPT x 3/4" HB
8	5089003	1	1/4" Square Keystock x 1 1/4" Long
9	5089033	1	3/16" Square Keystock x 1 3/8" Long
10	5120044	1	Shield
11	5152099	1	5.5 H.P. Engine w/ Gear Reduction
12	5271509	1	8-Roller Cast Iron Pump (Reverse Rotation)

